



Learning Environments



Contents

EDITORIAL	3
ISKU ACTIVE LEARNING	4 -
MULTI-PURPOSE SPACES	6 -
GROUP SPACES	22 -
LEARNING SPACES	30 -
CREATIVE LEARNING SPACES	46 -
TEACHER'S WORKING SPACES	50 -
LECTURE SPACES	54 -
INSIGHTS AND NEW TECHNOLOGY	60 -
TEACHERS' LOUNGES	62 -
LOBBIES AND HALLS	70 -
CANTEENS	74 -
LIBRARIES AND MULTIMEDIA LIBRARIES	80 -
DAY CARE CENTRES	82 -
ANTI-BACTERIAL LEARNING SPACES	86
MATERIALS	87
COLLECTION OF DESK AND TABLE TOPS	88 -



Tuoli 50

Design Kurt Hivitsjö

Isku's classic Tuoli 50 represents nostalgia for the 1950s, and it can be easily combined with modern furniture. The seat and backrest are available in either white or black laminate. The Tuoli 50 frame is available in various colours.



Focus on an environment inspiring learning

The majority of Finns have written their essays and calculated their calculations on a desk manufactured by Isku. We have accompanied the school attendance of Finns for over 60 years. Our story has been marked by the changes and phenomena of the society. Now we are involved in developing inspiring, functional learning environments where the developing technology and the most recent data on learning are taken into consideration.

Technology has changed human interaction and put learning spaces into a constant state of reform. Today, a learning environment is both a physical and virtual space. The teacher is in the middle of the learners and increasingly more often people sit in adjustable table groups or even on the floor on occasions. Mobile devices are used alongside traditional learning materials. Information is not handed down; instead it is searched for on the Internet, contemplated and applied. Learning takes place through own activity.

The Isku Active Learning environments inspire to learn. We are all individual learners. From the perspective of a functional learning environment, it is a positive challenge. We at Isku respond to this challenge by offering durable, individual and adjustable furniture solutions.

Finnish manufacturing and local production are important to us ever since 1928. Our products are designed by our own designers and freelance designers. We also provide a forum for young designers by collaborating actively with educational institutes. Isku takes pride in continuing the high-quality Finnish design tradition.

Our responsibility is reflected on the whole life cycle of our products. The wood we use originates from forests that are managed sustainably (PEFC). Water-thinned and solvent-free substances are used in wood surface treatment. In the metal parts we use a safe chrome plating technique. The fabrics do not contain harmful substances and are fire-tested to suit the location where they are used. Our packaging materials are recyclable. The annual volume of manufacturing waste ending up at landfill sites is less than that generated by the average Finnish apartment building. When our customers choose our high-quality furniture solutions, they become part of the Isku chain of responsibility.

Learning takes place everywhere – in homes, public spaces, and workplaces. Learning spaces are not restricted to schools. When we join forces with experts on learning and designers of functional spaces and we ourselves take into account the technological requirements, we have a Finnish educational export item at hand that provides inter-industry employment. Let us not waste this opportunity.

You are warmly welcome to explore Isku's functional Isku Active Learning environment! We will help you choose the best solutions for your specific learning environment needs from our extensive selection.

Arto Tiitinen
 Managing Director
 Isku-Group
 arto.tiitinen@isku.fi
 Tel. +358 400 566 875



Picture: Samsung

Isku Active Learning means functionality and communality

Digital devices and technologies change our operating environment. New technologies also present new challenges for the functionality of learning environments. Where pupils used to sit in rows, listen and learn by rote, today's school is a different, active functional entity. The emphasis is on interaction, inspiration and active pupils, environments and communities. Learning takes place through investigation and experiment, discussion and teaching others, and naturally also through watching, listening and writing. Learning is becoming increasingly multifaceted: online and manual, virtual and classroom-based, alone and together.

The new kind of functional and active learning poses new challenges for space use and furniture. Active functionality must be developed regardless of the location or shape of walls and spaces. Active learning and functionality thus also mean active learning environments. This creates practical challenges for learning environments.

Learning methods that favour new technologies and insight also create noise, life and a new type of communality. The starting point is an environment and community that activates pupils and inspires them to learn. Isku Active Learning solutions help accommodate and support changes in functionality, without requiring changes to the space.

Product innovations, which support functionality and promote activity, offer the opportunity to create areas for individual work, group work and interaction within a classroom. The carefully considered shapes and colours also help decrease unnecessary stimuli. Learning situations can be conducted individually, in small groups or with the whole class.

Active learning promotes critical information processing, diverse utilisation of information and its application. It also helps develop problem-solving, co-operation and communication skills. A creative and communal learning environment that serves pupils' needs must be considered in future curricula for preschool and basic education.

Conventional spaces must now be contemplated through a new perspective, in terms of functionality. Learning situations involve mobile devices, which are not tied to a certain place. On the other hand, power and re-charging the devices requires forethought and a systematic approach as well as alternative solutions. It is also important to ensure that pupils have sufficient desk and storage space. Pupils switch between learning tools mid-class, and the changeover must be seamless. An active and adaptable learning environment takes all this into account.

More and more often, learning takes place in groups of various sizes and different interactive situations. Isku Active Learning products have been specially designed to be easy to move, group and dock in different configurations in changing situations, which encourages varied individual and group work. Individual work can smoothly segue into group work projects, and the lesson can easily continue on the floor. Move aside the furniture, and learning can continue on Kivikko seating or Mukula cushion seats, for example. The geometric shapes of Mukula cushions help visualise mathematics, and the cushions can also function as sound insulation: equipped with magnets, Mukula cushions can be mounted on walls as acoustic elements.

The action-oriented learning environment of Isku Active Learning can smoothly adapt as needed. It also inspires ideas, frees thinking and motivates both pupils and teachers.

It is difficult to predict the future conclusively. Products, materials and designs must stand the test of time; products must be safe to use and adaptable for changing situations and the needs of several generations. Isku, an expert of furniture for learning environments, has adhered to these basic principles for over 60 years.

Welcome to the new and functional world of learning offered by Isku Active Learning!

NEW



Kivikko seat
Osio table
Salsa sofa

Functionality into multi-purpose spaces

The shared multi-purpose spaces of schools are also learning environments. With the right furniture solutions, they can be utilised for learning by pupils as well as mature students. Adjustable spaces are great for working together but they can also contain a calm spot for individual learning.



Ecological choices

We put a lot of thought into making ecological choices both in raw materials and production. The Kivikko seating produced for public spaces can be used to create free-form seating groups for users of all ages.



Kivikko
Design by Henri Halla-aho



Height 73 cm



Height 55 cm

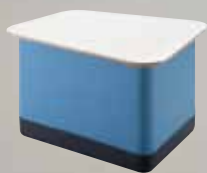

Kivikko with fabric plinth

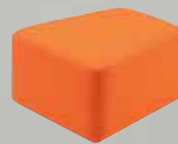

Height 26 cm

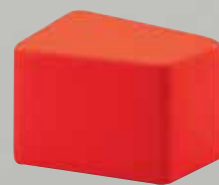

Height 40 cm

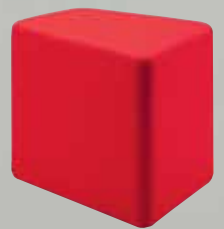

Height 54 cm

Mukula
Design by Kaija Aalto
Kivikko seats



Salpakangas School – Kivikko and Mukula

Award-winning functionality

The Mukula cushion seat wall was created in spring 2011 as part of a student project organised jointly by Aalto University and Isku to seek new ideas for future learning environments. Mukula consists of cushions on which you can sit on the floor and then lift onto the wall after use. The cushion seats are attached by magnets to a metal plate, whiteboard or, say, electrical installation ducts on the wall.

Mukula is a fresh new option for studying. It constitutes a sound-absorbing element in the room while adding colour and variety to the interiors. The cushion seats are available in various colours and in circle, ellipse, square and triangle shapes. They can also be used in teaching situations: the children learn to identify and arrange shapes and colours with the help of Mukula.



3747-550
Height 7 cm



3747-502
Height 16 cm



3747-500
Height 16 cm



3747-506
Height 16 cm

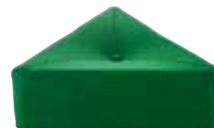

3747-504
Height 16 cm



3747-602
Height 23 cm



3747-600
Height 23 cm

Versatility



Syke sofa
Design by Mikko Laakkonen

Space Chicken table
LoOk Industries

Aurinkovuori School, Asikkala



Aurinkovuori School, Asikkala

Dyyni sofa
 Design by Tapio Anttila
 Swing sofa table

Adjustable module sofas create diverse sofa groups in the school's different spaces that are functional in view of the purpose of use of the space. Various fabric choices and by combining different modules can be used to create a customised sofa set that best fits the space in question.

The Syke lobby sofas have backrests and armrests with different shapes and sizes that add character and a nice rhythm to this otherwise simplified and streamlined piece of lobby furniture.

The seat components of the Dyyni modular sofas can be used either with the armrest and backrests or without them. The series comprises one, two or three-seater modules and a sofa table with a magazine slot and shelf.

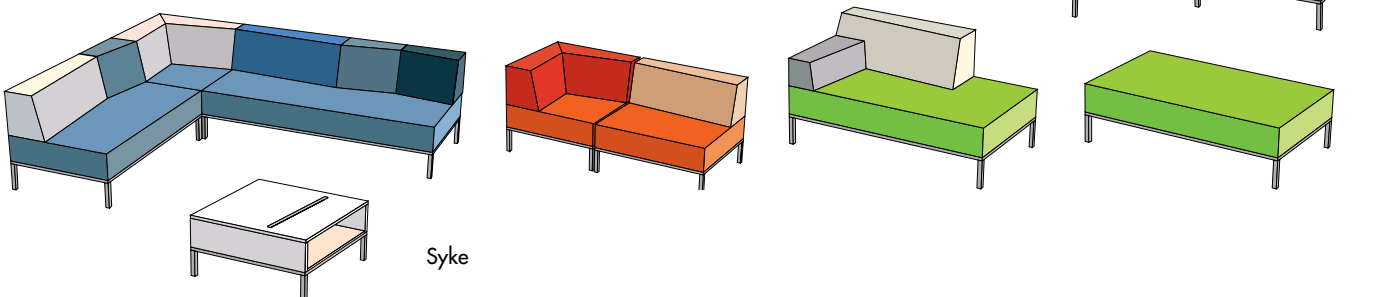

Acoustics into open spaces



Inkoo Pro High sofa
Design by Ilari Jaaskeläinen

Kivikko seats,
Kivikko tables



The Inkoo Pro High sofas and Kivikko seats serve as sound-absorbing elements. The Inkoo Pro High sofa meets the requirements of absorption class C. The sofas can be used to create a private, calm space for group work and meetings. The role of the Inkoo Pro High sofas in interior design can be emphasised by the use of two colours in the upholstery.

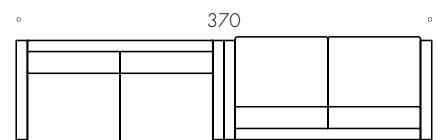
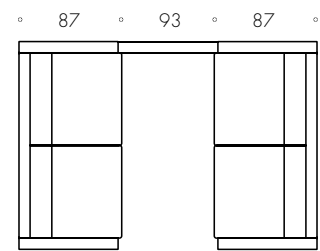
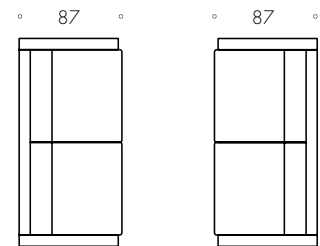



Kaari
Design by Henri Halla-aho
Space Chicken table

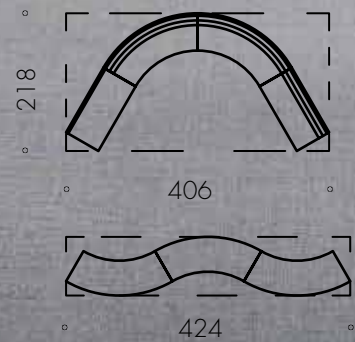
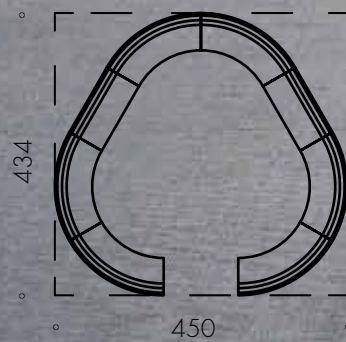

Calm space division

The Kaari sofa system creates intimate discussion and working areas in open work environments, such as lobby areas at schools or in group work areas. The Kaari sofas can be used to create peaceful closed groups or continuing shapes by combining straight and curved elements. Accessories are available.

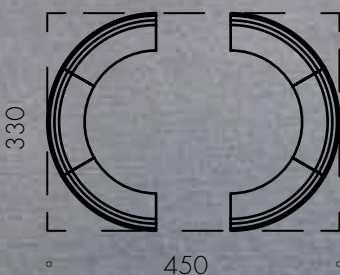
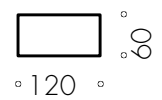
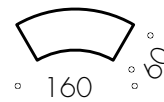



The Box Lounger chair
Space Chicken table
LoOk Industries

THE BOX LOUNGER 29895

Little More Bean Bag chair
Stoppelit



Playful use of space

Representing innovative Finnish design, LoOok Industries is Isku's partner who has received much positive attention with their individual and young designs. The concept emphasises a playful and creative use of space in designing learning environments where the products serve also as acoustic elements.



WOODLAND HIGH
29898

Woodland High tree

Signs sofa
Space Chicken table



SIGNS 29894



Aurinkovuori School, Asikkala

Move gas-spring table
Prima/Mac working chair
Kivikko seat
Tendo Oppi storage system



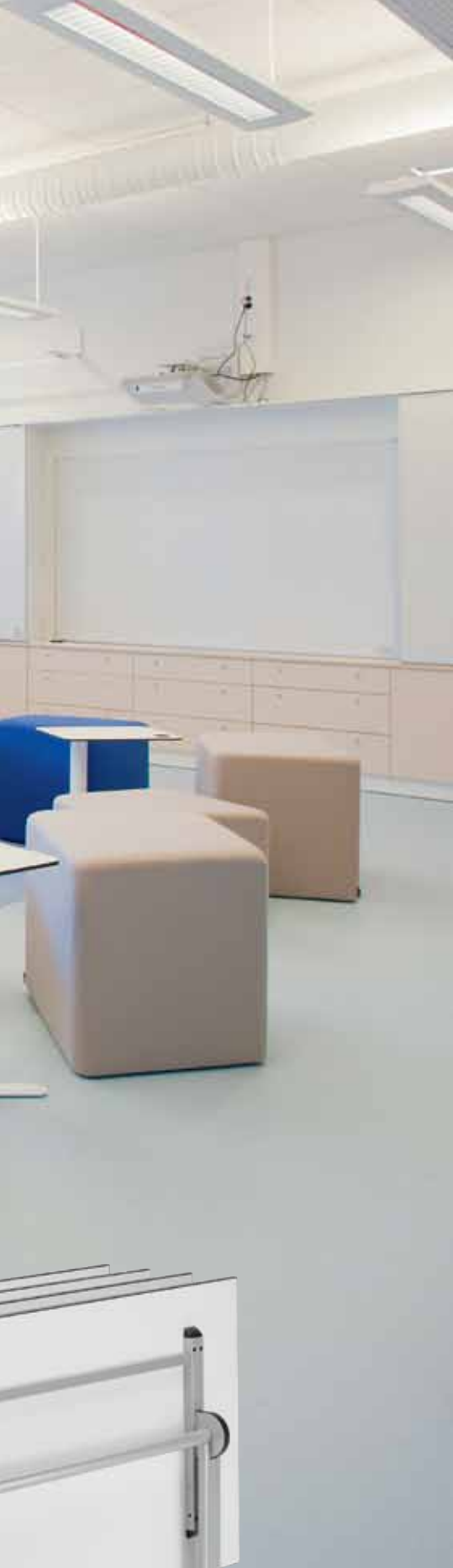

Move-gas spring table
ILOA+ chair

Move folding-top table
Matti chair



Aurinkovuori School Asikkala



Move folding-top table

Multi-purpose space solutions

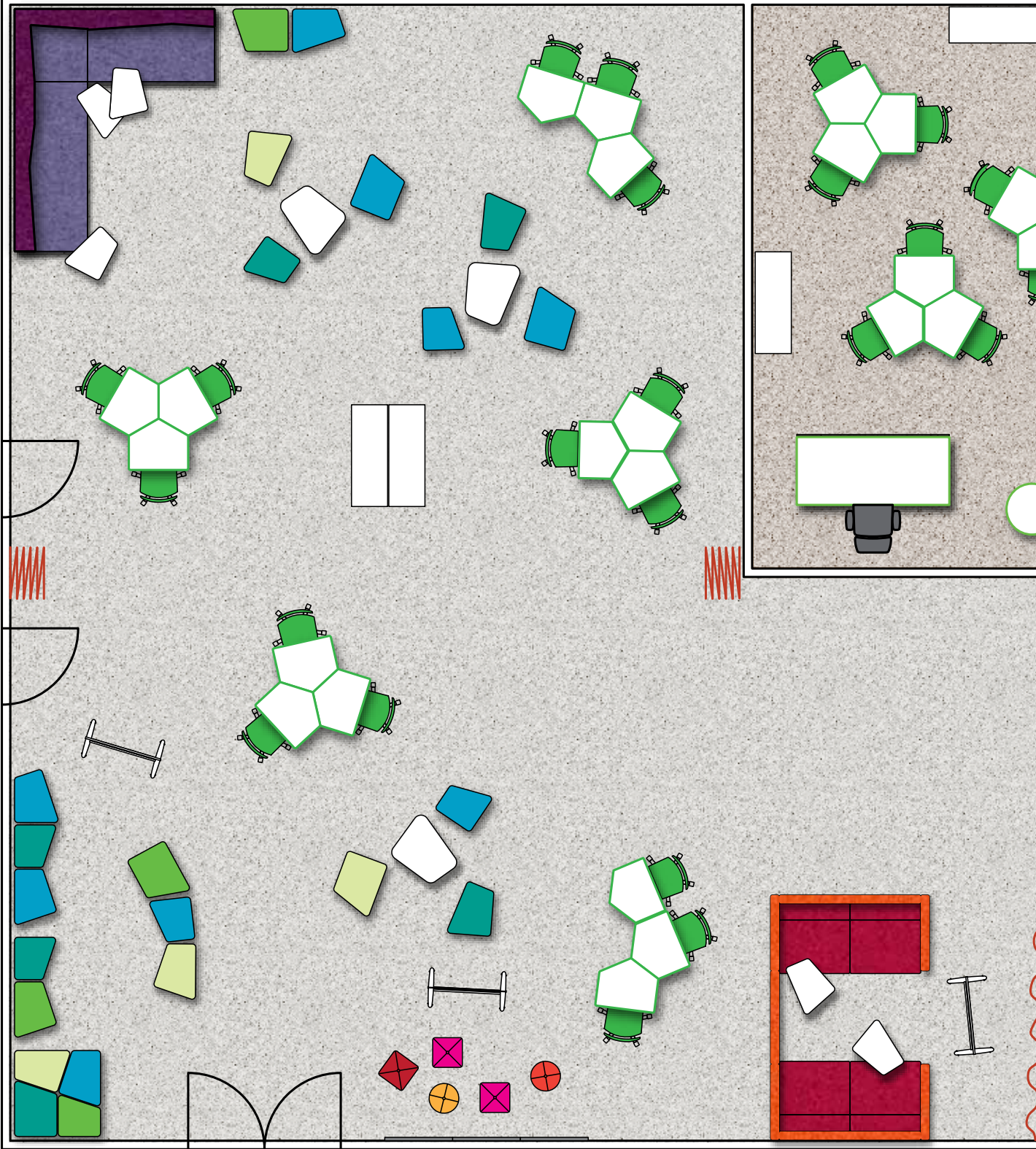

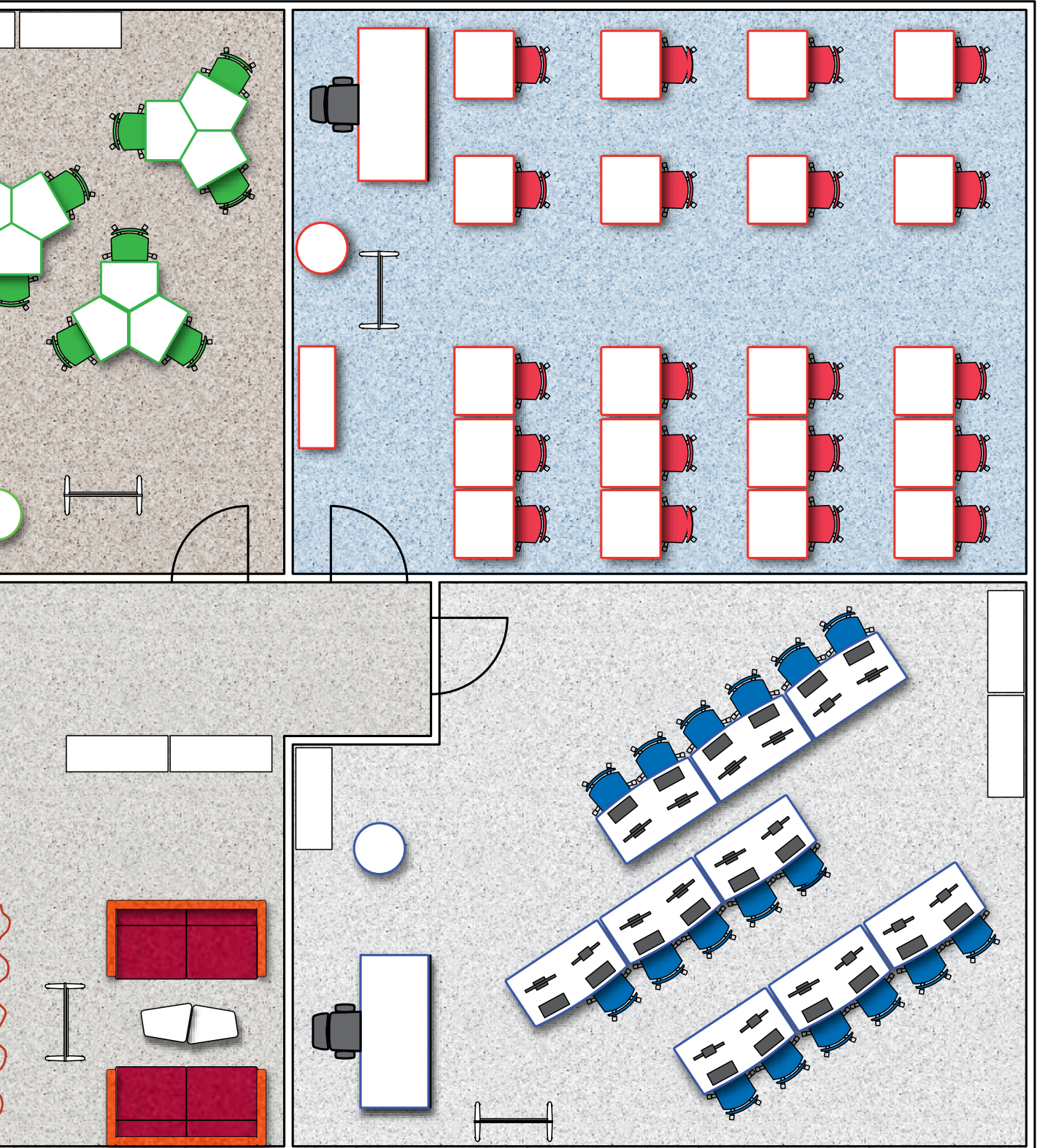



Summa GA table
Mac-working chair



Remember the
math exam on Thursday!

Shared joy of learning

Diverse group work points can be quickly created in a classroom with Summa classroom desks and chairs. The desks and chairs are light to move. Due to their design, the group work points have a sense of posture. Now and then, pupils can enjoy the comfort of the Mukula seats. When attached onto a partition, they serve as acoustic elements of the space.





Summa GA

Size of example classroom: 60 m²

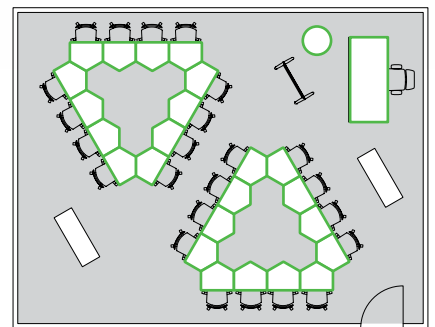
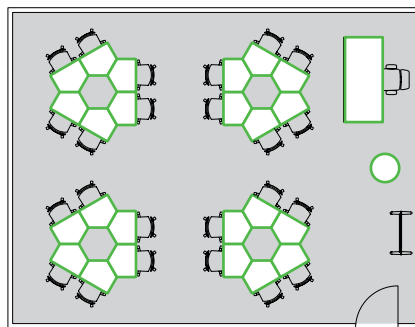
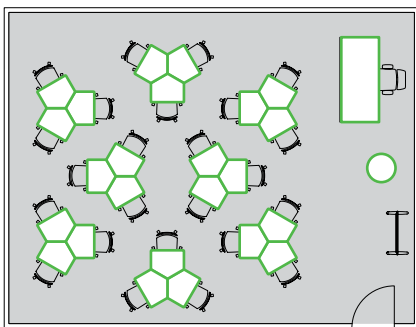

Why should you select a cast edge for the top of a classroom desk?

A cast edge is extremely durable and resilient, which gives the top a long service life. The cast edges are tight and seamless, because the edge has been cast into the structure of the top. There are several delicious and cheerful colour options available for cast edges, which can be used to make the teaching environment unique.

The **Summa GA** classroom desk is an excellent fit for both individual and group work. Several different group work arrangements can be created with the GA desks. Desk top size: 70 x 60 cm. The legs of the desk can also be equipped with castors, which make it easy to move the desk. A basket placed under the top is available as an accessory.



Summa GA
Teamix GA



Summa Teamix-
GA + basket



Summa Teamix GA +
basketMac 3008

COLOUR OPTIONS OF CAST EDGES:



Birch 91



Beech 92



Green 93



Red 94



Grey 95



Blue 96

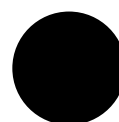

Black 29

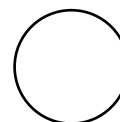

White 28





Summa GB

Size of example classroom: 60 m²

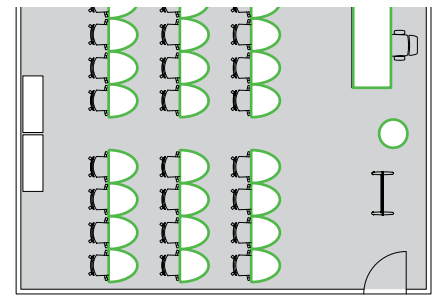
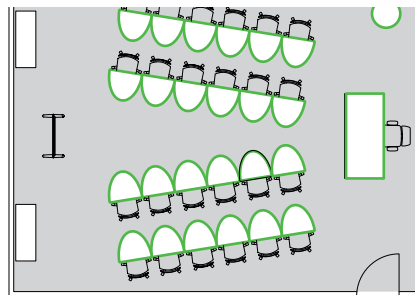
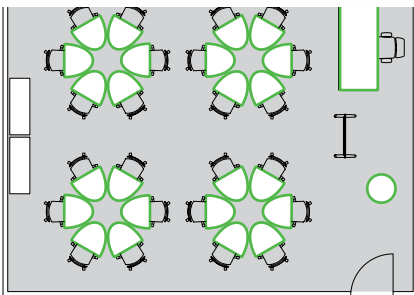

Why choose a classroom chair with a laminate surface, castors, and height adjustment with a gas spring?



Summa GB

A student can quickly and easily adjust the chair to the correct height by using the height adjustment with a gas spring. A chair equipped with castors and a base is easy to move, and it is flexible in a teaching situation where the direction of view and location of the teaching changes. Laminate is an easy-care, durable material. Laminate colour options: white, black, blue, red, green, light grey, dark grey, birch, beech, oak and anthracite.

The **Summa GB** classroom desk is suitable for a classroom that changes from individual work to group and lecture mode as necessary. Desk top size: 70 x 60 cm.

STUDENT CHAIR OPTIONS:



Mac 3008



Mac 3008



Tutor 3010P



Tutor 3010



Tutor 1035



Tutor 1035



Prima 1030



Summa C14

Size of example classroom: 60 m²

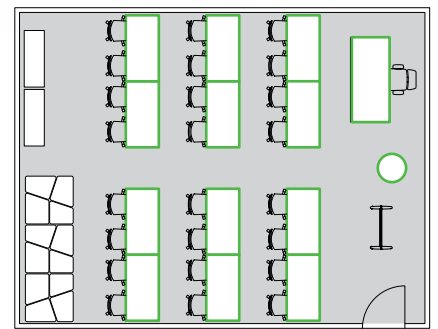
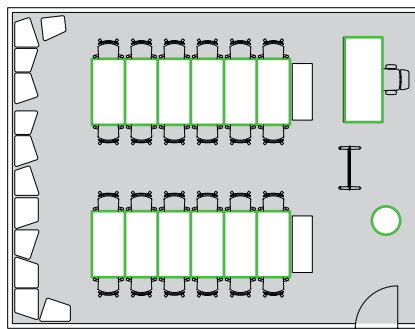
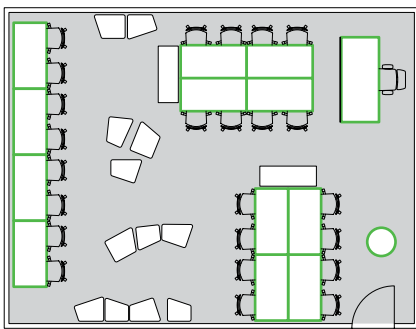

What kind of alternative and inspirational work stations can be placed in a classroom?

Soft interior design elements create comfort in the interior, and they also provide an opportunity for group work in places other than the classroom desks. The shapes and colours of the soft seating elements provide inspiration for creative group work. The use of soft elements also improves the acoustics of the space.

By combining **Summa C14** tables, large group work tables can be created for visual arts or crafts classes, for example. The desks can be arranged to suit group work or a lecture room. Desk top size: 140 x 70 cm.

KIVIKKO - DIFFERENT SHAPES:





Summa GH / GF

Size of example classroom: 60 m²

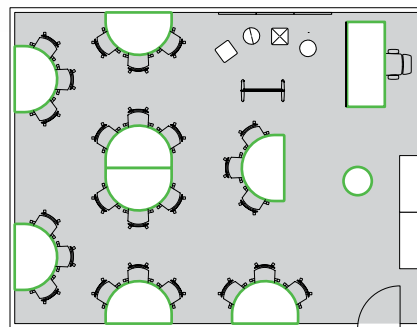
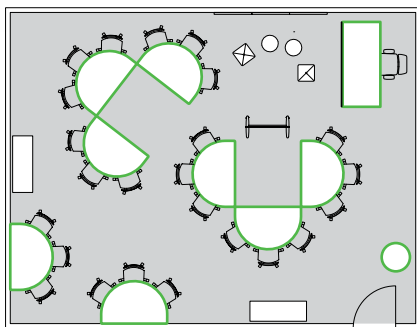

How can a classroom be divided quickly and efficiently?

The storage units in the Tendo Oppi series can be used to divide the classroom. The storage units can be equipped with lockable castors, which make it quick and easy to move them inside the classroom from the sides to the centre of the room as needed. This creates new functionality for the classroom. The back of the storage units can be upholstered, which makes it possible to attach drawings to the surface, for example. A storage unit can be combined with doors, sets of drawers, and open shelves.

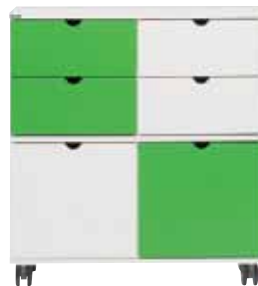

Summa GH and **GF** tables are a solution when you want a group work area with several group work stations. The tables can be placed either next to a wall or combined next to each other or arranged into small groups, which creates a meeting setting. Desk top sizes, GH: 140 x 90 cm, and GF: 120 x 90 cm.

COLOURS FOR TENDO OPPI STORAGE SYSTEM MDF DOORS AND FRONTS



MDF-IC Grey

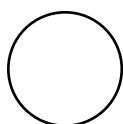

MDF-IC White



MDF-IC Blue



MDF-IC Green



MDF-IC Red

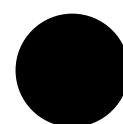

MDF-IC Black



Summa GR

Size of example classroom: 60 m²

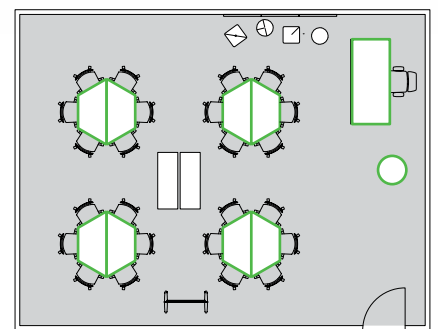
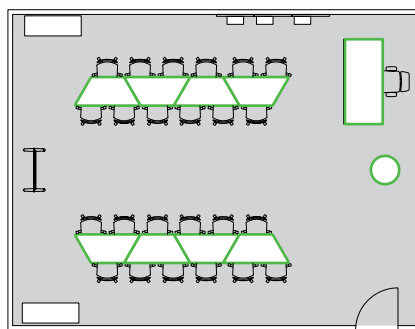
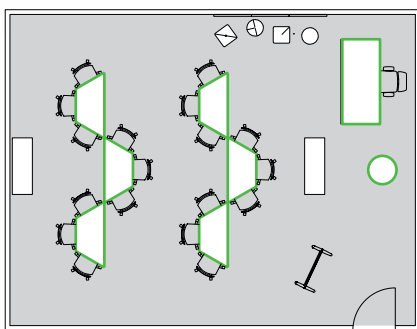

Which interior solution will be visually effective and create new functionality in a space?

The Mukula cushion seat wall is a visually effective, fresh option for studying. Mukula includes cushions of different shapes and heights, which can be used for seating on the floor, and which can be lifted onto the wall for storage after use. The seat cushions are attached to the Mukula wall element with a magnet. The Mukula cushion seat wall also improves the acoustics of the space by acting as a sound-absorbing element. The seats can also be used to teach geometric forms. The shapes of the Mukula seat cushions are: square, triangle, circle and ellipse. The seats come in three different heights: low, medium and high seat.

The **Summa GR** table uses space efficiently, thanks to its shape and size. The GR table is particularly well suited for group work areas where the tables can be combined into different kinds of group work stations. The shape of the top is one of the best features of the GR table. There is enough room to work on each side of the table. Table top size: 140 x 61 cm.

MUKULA - DIFFERENT SHAPES AND HEIGHTS:



3747-550
Height: 7 cm



3747-502
Height: 16 cm



3747-500
Height: 16 cm



3747-506
Height: 16 cm

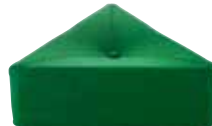

3747-504
Height: 16 cm



3747-602
Height: 23 cm



3747-600
Height: 23 cm



Aurinkovuori School, Asikkala



Summa Teamix GA table
Mac/Prima working chair

Homework
p. 21-28

Prima table
Prima chair
Matrix T EL electrically
height-adjustable desk

Joy of self-learning

The classroom workstation is a dedicated nest of learning for the young pupil. A safe haven that provides peace and quiet when concentration is required. At the same time, it is great for training individual learning. It is, after all, also part of school attendance.





Prima table
Tutor chair
Aava sofa

Saunalahti School, Espoo



Prima 1126, 4-6



Prima 1132, 4-6



Prima 1128, 4-6



Prima 1130, 5-7



Prima 1131, 5-7



Prima 1131, 5-7



PRIMA DESK TOP SIZES:

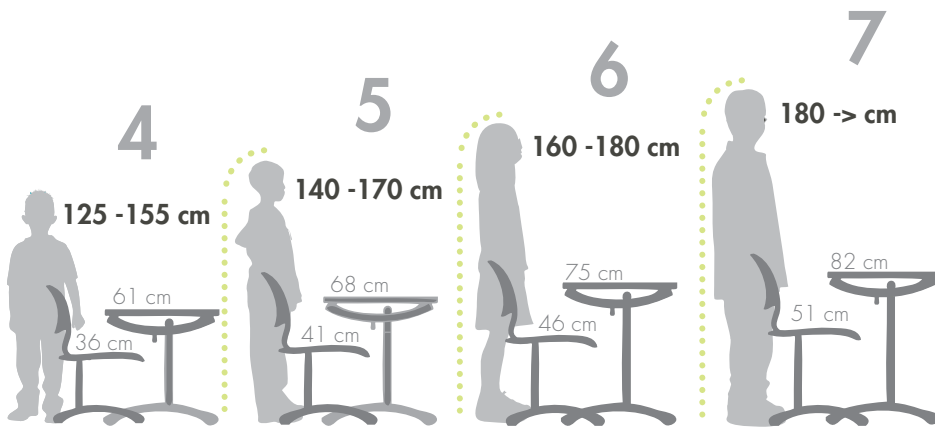

top only	with a box
Prima 1131 700 x 600*	Prima 1132 650 x 580*
Prima 1130 700 x 500	Prima 1128 650 x 500*
tilting	Prima 1126 600 x 500





Espoonlahti School, Espoo

Prima table
Prima chair

PRIMA CHAIR 1030

PRIMA WOOD AND PLASTIC COMPOSITE CHAIR 1030



Prima 1030, 4-6

Prima 1030, 5-7



Prima 1030, 5-7
beech colour

Prima 1030, 5-7
birch colour



Prima 1030, 5-7

Prima 1030, 5-7

Prima 1030, 5-7

Prima 1030, 5-7



Mac 3008



Mac 3008



Mac 3008



Mac 3008



Mac 3008



Mac 3008



Mac 3008 FR
wood and plastic
composite



Mac 3008



Tutor 1035, 5-7



Tutor 1035, 5-7



Tutor 3010



Tutor 3010 C



Tutor 3010 FR



Prima-studenti desk ja
Tutor-student chair

Aurinkovuori School, Asikkala

Summa Teamix GA table
Mac/Prima working chair



Matrix Y Tall desk table
Tutor working chair

Ergonomics with high furniture

Ergonomics for both pupils and teachers. The teacher is no longer in front of the class but rather in the middle. When the furniture is higher, the teacher does not have to bend over. The teacher can walk among the pupils to instruct. The furniture is also ergonomically proportionate for bigger pupils and students. The Mandal Prima pupil furniture has two different working positions: a listening position and a reading and writing position.





Summa C8

Size of example classroom: 60 m²

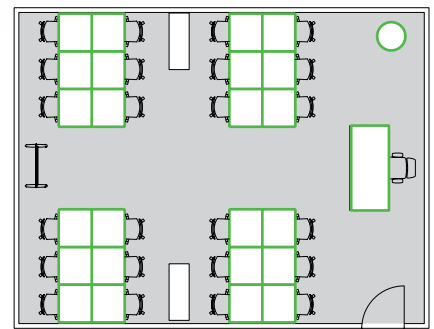
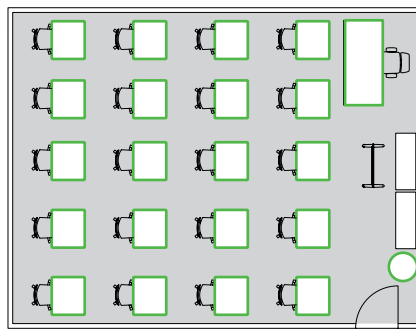
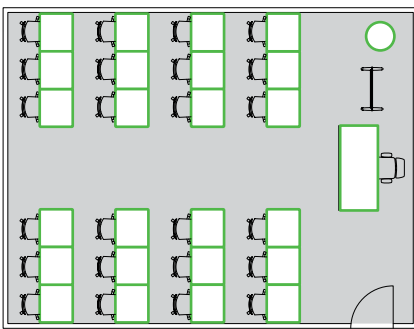

In what kind of a room can you use high classroom desks and chairs, and what benefit is there in using them

A high classroom work station is suitable for all teaching environments. The benefit of a high work station is that the teachers do not need to bend down when they instruct the students. The teacher's working posture at a high desk is ergonomic. The chairs for a high working station have a footrest or a foot support ring and the chairs have a height adjustment with a gas spring, which makes it possible to adjust the chair to suit the user quickly and easily.

The **Summa C8** table is designed for individual work, but it is also suitable for lecture and group arrangements. The top's depth of 70 cm works particularly well in areas where tables are used to handle large drawings or materials. The C8 tables can also be equipped with high legs as an option. Table top size: 80 x 70 cm.



Tutor 3010 FR



Mac 3008 FR



3016 M FS



3060-510
Still S1A 21 FR



Tendo AV



Aurinkovuori School, Asikkala

Matrix Y Täll desk table
Mac/Prima working chair

Active sitting



Mandal Prima table
Mandal Prima chair

Puistokoulu School, Jyväskylä



The Mandal method of working is based on two different working positions. Changing sitting positions activates the muscles and accelerates blood circulation, thereby keeping you alert. The tilting table lid reduces neck tension. Mandal furniture has special properties, such as the forceful bending down of the seat front edge that entices you to change your working position.





Matrix Frame table
Mandal Prima chair

Espoonlahti School, Espoo



Matrix I Tall ja Mandal Prima



Mandal Prima 1051



Mandal Prima 1051



Kid 29633

Mandal Prima



In the reading and writing position, the student works in a half-seated position, with their feet on the floor or on an adjustable footrest. This will open the angle of the pelvis and improve blood flow to the lower extremities.

In the listening position, the student is seated leaning on the backrest, with their feet on the footrest of the chair. For furniture with a high seating point, it is essential that they are suitable for students of different heights and that the teacher has an ergonomic working position next to the high table.

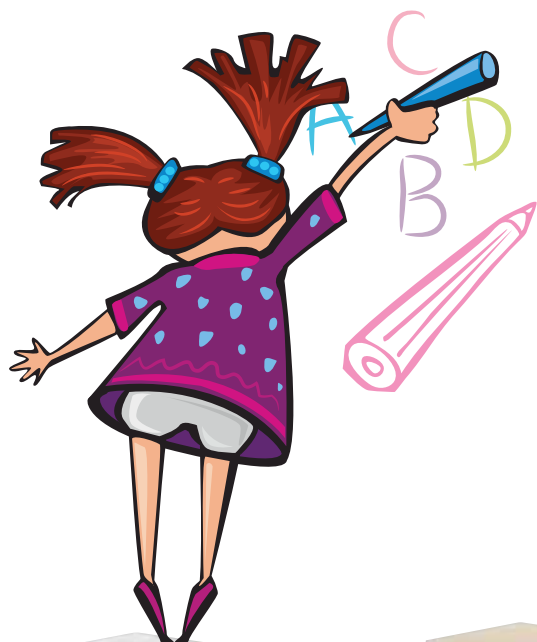

Mandal Prima, fixed seat height				
Height of student (mm)	1550	1400-1700	1600-1800	1800-
Height number	3-4	5	6	7
Height of seat (mm)	650	650	650	650
Width of seat (mm)	360	420	420	420
Height of footrest	1)	1)	1)	1)
Height of desk (mm)	850/900	900	950	1000
Height of footrest	2)	2)		

Setting the footrest:

- 1) When sitting in the 'listening' position, the student's knees should be at an angle of about 90 degrees. Set the chair footrest to the level of the soles of the feet.
- 2) Set the desk footrest so that it is 100-130 mm lower than the chair footrest.



Mandal Prima 1131
+ footrest



Mandal Prima 1131
+ chair support



Mandal Prima 1132
+ chair support + footrest



Mandal Prima 1131
+ chair support + footrest



Tendo Oppi storage system

Getting organised

The versatile Tendo Oppi series has different storage options for both learning and office spaces. The storage units also function as room dividers, and they can be equipped with upholstered back panels that can be used as attachment surfaces. The Tendo Oppi storage units come in several colour options, which create a refreshing impression of the interior. The storage units are available equipped with lockable castors, legs, or a base.



Tendo Oppi 4F



Tendo Oppi 6J



Tendo Oppi 6G

Joy of manual skills



Matrix Y Tall table
Tutor chair

Karisto School, Lahti



Room for creative work and manual skills with large table top surfaces and ergonomics for work with high workstations.



Salpakangas school, Hollola



Karisto School, Lahti



Mandal Prima chair
Matrix Frame table

Espoonlahti School, Espoo



Prima chair
Matrix Frame table

Matti chair
Matrix Y table



Matrix T EL electrically
height-adjustable desk

Salli saddle chair
Tendo storage tower



Summa GN

Size of example classroom 60 m²

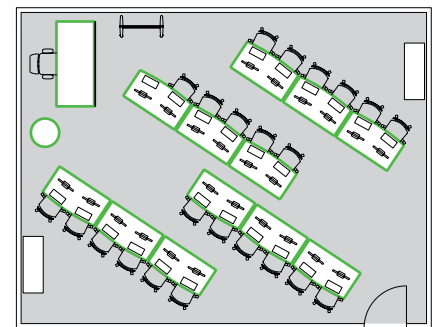
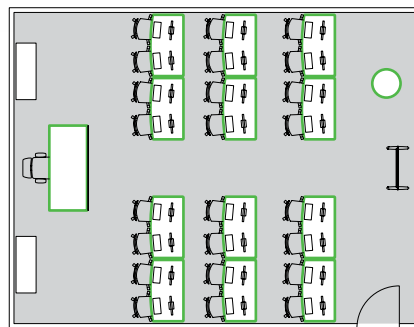
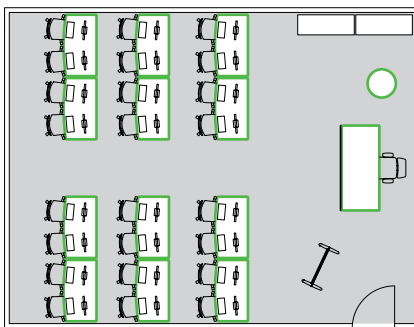

WHAT issues should be taken into account in designing a teacher's work station?

The collection offers several options for a teacher's work station to suit every user's needs. Considering the ergonomics of a teacher's work, a desk with electric height adjustment and an office chair with versatile adjustment options are the best solution. This makes it possible to work at the work station either standing up or sitting on an office chair. There are office chairs with a wide range of adjustments available; these chairs are suitable for working at a higher level. A front panel with an upholstered or plain board surface can be selected as a screen for the legroom and cables under a teacher's desk. A CPU rack, cable baskets or chutes as well as a cable pass-through can be added to the desk as accessories.

The **Summa GN** table for two people is ideal for media classrooms and media libraries. The curved shape of the front edge of the table provides the people sitting at the desk with their own work areas and their own share of the table. The GN table also works very well in lecture rooms, where the people sitting next to each other need their own section of the table. Desk top size: 130 x 70 cm.



29701-551
Salli MultiAdjuster



3061-700
Still S1A 21



3061-712
Still S1A 22 + armrests



3062-570
Still S2 28 + armrests



Matrix T EL 2060 +
2836 Mode front panel



Matrix I 2057 +
2836 Mode front panel



Espoonlahti School Espoo

Matrix T EL electrically
height-adjustable desk

Prima chair
Matrix Frame table

An electrically adjustable standing desk is an ergonomic choice for the teacher and by combining it with a fix-legged desk more table top area is gained. This workstation is functional and provides ergonomic variation.



Matrix T EL electrically height-adjustable desk
Matrix I table
Still working chair
+ Tendo Oppi Storage System

Laukaan Kirkonkylä School, Laukaa



Functionality for all spaces

NEW PISA PRODUCT FAMILY!

"The functionality and insights of the design as well as high-quality local production are important values to Isku," says Design Director Antti Olin.

The Pisa product family is a new addition to Isku's product range that is suited for learning situations that require adaptability from the learning environment. Especially the design of the Pisa series has emphasised functionality; the product family is designed by design company Desigence.

The lightweight desks and chairs are easy to assemble to form group learning environments and to disassemble for individual learning. A smart attachment mechanism makes it easy to link the desks in a traditional row.

The chairs and tables of the Pisa collection are light and easy to stack. With the help of the hanging feature, the chairs are easy to attach on the table top. Isku's extensive laminate collection can be utilised in the tables and chairs of the series.





Pisa lecture table and
-chair
Design Desigence

Tendo Oppi storage system





Klik-table with folding legs
Signum armchair

Klik 2-H lecture table
Minus chair

Logo armchair
with writing pad



Alandica, Maarianhamina



Fellmannia, Lahti



Autotalo Laakkonen, Helsinki



Open-mindedness and insights through experimentation



Pupils are sitting tablets in their lap on chairs, cushions and stools with an air of concentration. Many subjects are studied at the same time. They play as well as advise and teach each other. They move around and laugh but keep it down. At the end of the class, desks are arranged for small-group discussions. It is possible in the future learning environment.



The learner plays the lead in the Isku Active Learning concept: his or her emotions, motivations and own activity. Learning is a state of mind that is greatly impacted by the physical space. It impacts the adoption of information, insights and innovations.

The culture of teaching and learning is developed via adjustable and flexible teaching space solutions. Active learning ecosystems have been built around the globe for a long time. So have we at Isku.



We have contemplated the appearance of an environment that will inspire learning in the future. As a result, we have created, amongst other things, the Inkoo Pro High sofas and partitions that improve acoustics and the acoustic Kivikko and Mukula seats. Functional furniture adds sympathy, lightness and volume to the space.

Trolley

Design Sebastian Jansson

The newest addition to Isku Active Learning is the Trolley concept designed by a young designer Sebastian Jansson. The key idea behind the design is open-minded functionality, mobility and stacking that enable diverse use of learning spaces. The pupil's workstation is exactly where it needs to be at that moment. School supplies can be packed into the chair's storage basket, the chair can be moved around and stacked to save space. The mono-colour and harmonious colour scheme of the furniture is soothing and clarifies the visual look of learning spaces. Trolley inspires and ensures calm work in every space.



Technology and different ways of learning and teaching are present in future learning environments. They have multiple uses, are adjustable and serve people of all ages. Daytimes are for learning but evenings can be about something completely different. Furniture must suit different purposes of use, inspire and be able to touch users even after decades.

New technology to support learning

Technology has changed learning environments and operation modes for good. The technological development is fast and, therefore, it must be ensured when making acquisitions that the entity can be utilised for a long time and that the acquired technology does not isolate different functions. Technology and different ways of learning and teaching are increasingly more present in the future learning environments. Regardless of the renewing operation environment and technical equipment, the main focus remains on the traditional elements: the learner and teaching. Gaining insight and guiding insight are at the focus when functionality and possibilities increase.

Technology is not the key; it is used to support learning. Isku's partner Samsung has lent its expertise when the Isku Active Learning concept has been developed to meet the future needs.

Picture: Samsung



Communality

Functional spaces let teachers focus on their work and enable social interaction. A comfortable teachers' lounge is an important working space. It is used for meetings and the ergonomically designed workstations ensure the peace and quiet needed for work. Correctly selected materials improve acoustics and create a relaxed atmosphere. Comfortable seating groups are great for exchanging experiences, thinking of new ideas and creating a sense of togetherness.

Tere easy chair
Rudolf chair
Sigur sofa table





Kiviniemi School, Oulu





Dynni sofa
Sigur sofa table
Still working chair
Matrix 1 -table



Laukaan Kirkonkylä School, Laukaa



Inkoo Pro sofa
Swing sofa table
Ritz easy chair
Osio table
Rudolf chair



Puisto School, Jyväskylä





Kantti table
Organo easy chair
Rudolf armchair





Matrix 1 conference table
Signum conference chair



Valkeakoski High School, Valkeakoski

Halls



Matti chairs
Kivikko seats



Lightness
Design by Samuli Naamanka



Versatility for every space

The Lightness chair family has focused on functionality, good design, and carefully finished details. The strong, plastic forms of both the seat and backrest are created with the Grada material and good design.

The efficient stacking and the light, strong structure make the Lightness chair ideally suited for many different purposes.

*Grada is an entirely new material with a special adhesive film that enables the thermoforming of the composite wood panel. The method is much simpler and faster than conventional pressing to shape. It is suited for automatic production and provides a firmer and stronger structure. The adhesives are environmentally friendly, and the material can be recycled at the end of its lifespan.

For example, the Lightness, Kaava and Duo chairs in the Isku Interior furniture collection for public spaces are made out of Grada.





APC chair
Matrix table

Flexible canteens

Shared spaces are important learning spaces but also multi-purpose spaces serving other activities. During the day, pupils enjoy their lunch in the canteen. In the evenings, the space is used by others. Shared spaces stay tidy and adjust to needs when the furniture can be moved around, stacked and hung.





Moni table
Matti chair



Espoonlahti School, Espoo



Safe functionality with colours!

Learning spaces should be stimulating and inspiring, and playing with colour gives a new look to the spaces. Colour can also be used to help structure spaces, amongst other things, which is very important when learning the school's emergency exit routes, for example. Coloured laminate surfacing is easy-care and durable, which makes it an ideal surface material for products used in a learning environment, such as chairs and desks.

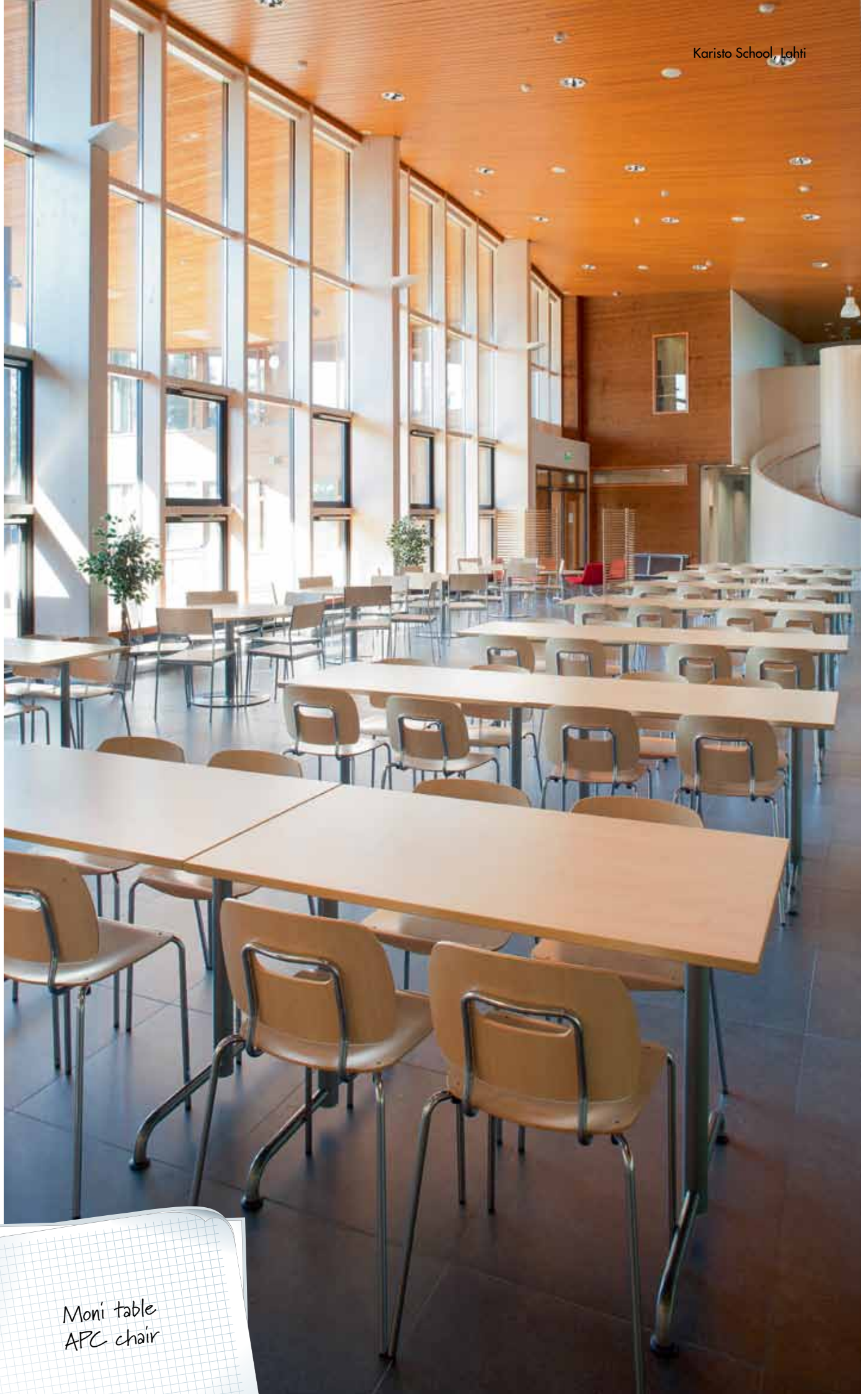

Moni table
APC chair



University of Applied Sciences Lahti

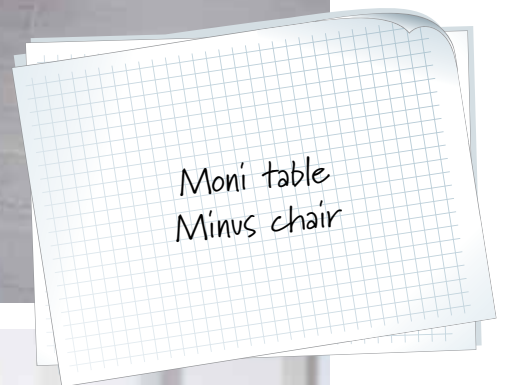

Thirst for knowledge



The world is not ready, new information is generated constantly. There is no need to manage all information but you have to be able to search for it and apply it. The lighting and colour choices of libraries attract to the world of knowledge. Lightly moving chairs and the material choices respect the harmonious atmosphere of libraries.



Dio table
Matti chair



Otto children's furniture
Isku Avec Collection

Learning by playing!



Huhtasuo Day Care Centre, Jyväskylä





Inkoo Pro High sofa
Mukula seats



Otto-kid's furniture
Isku Avec Collection



Laukaa Day Care Centre, Laukaa



Interrupt the chain of infections in the school world

Anti-bacterial furniture improves the hygiene safety of learning environments.

Where there are many people there are also bacteria. Handles, knobs, chair backrests and surfaces touched by pupils contain bacteria. A sneezing pupil spreads the pathogen usually via surfaces: to the teacher, to classmates, from school to home and to parents' workplaces.

Isku's anti-bacterial furniture improves the hygiene safety of public spaces.

The antibacterial properties of copper and silver have been utilised in coatings. The materials available include copper-based coatings as well as laminates, lacquers, paints and fabrics treated with anti-microbial agents.

When surfaces of public spaces are anti-bacterial, the number of bacterial infections is reduced by approx. 60%. That is a significant number from the perspective of society. When a safe and anti-bacterial environment is needed, Isku can help you.



LACQUERS, NATURAL COLOURS METAL COLOURS

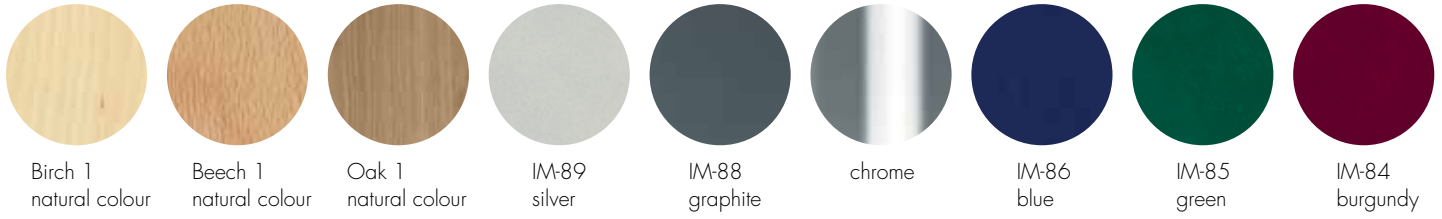

LAMINATE



WOOD AND PLASTIC COMPOSITE COLOUR OPTIONS

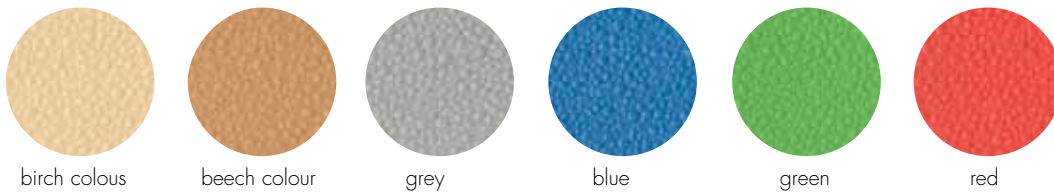

POLYPROPYLENE COLOURS FOR Mandal Prima- ja Kid-chairs



* Prima chair also available in polypropylene, colour burgundy red

MELAMINE



COLOUR OPTIONS FOR CAST EDGES

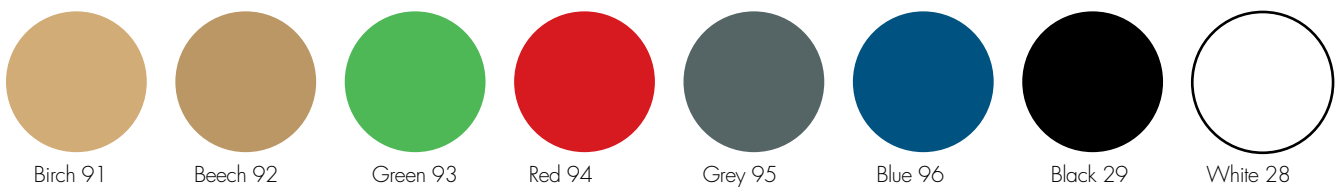

COLOUR OPTIONS FOR TENDO OPPI MDF DOORS AND DRAWER FRONTS

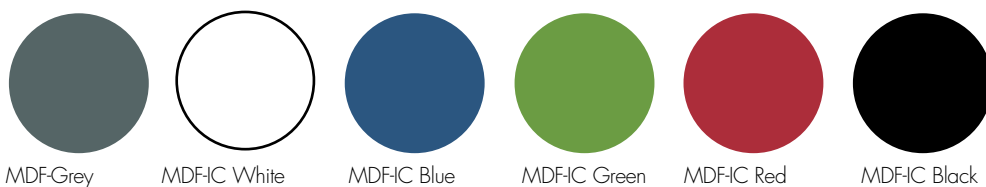

The availability of materials differs for each product. Due to print technology, the colours do not completely represent the actual colours.

ISKU INTERIOR'S COLLECTION OF DESK AND TABLE TOPS

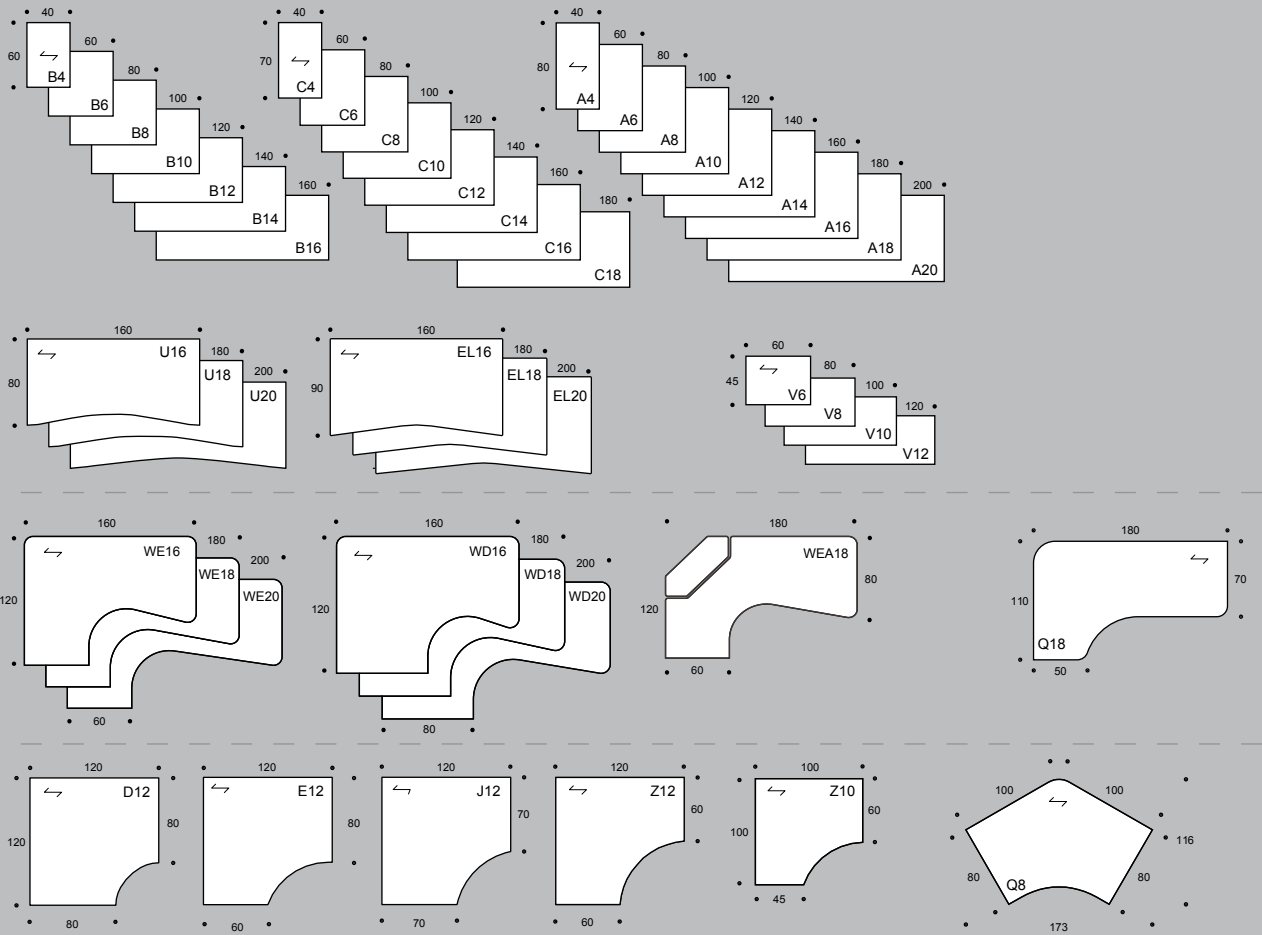

TOPS FOR TEAMWORK TABLES

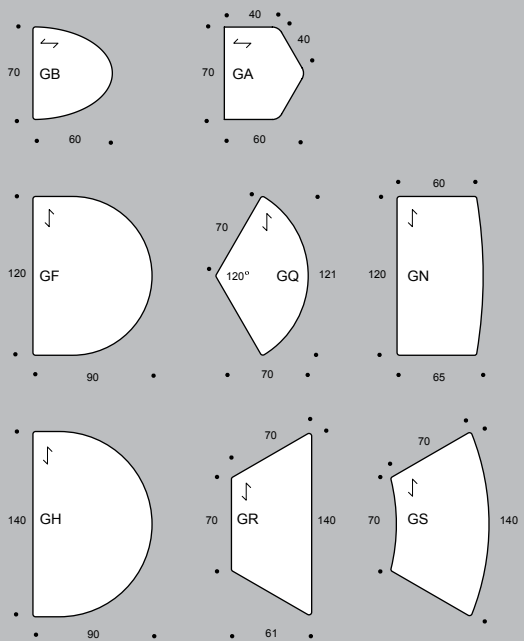

ISKU INTERIOR'S COLLECTION OF DESK AND TABLE TOPS

The tops are made of 26 mm thick furniture board or MDF. Asymmetrical tops are shown as left-handed versions. Right-handed versions are also available. The beech-veneered tops can be stained with Isku's standard furniture stains. Veneered EL and P table tops are made of MDF board with bevelled and lacquered edges. Mel 130 grey, lam 215 and lam 230 EL and P table tops have ABS edging strips. Flat screen monitors can be sunk into the table top with the help of the Screen-center. -marked tops in birch, beech, lam 230 grey and lam 215 white are available with express delivery. The direction of the veneer in the veneered tops is indicated by the symbol ↵

TOPS WITH CAST EDGES (TEAMIX)

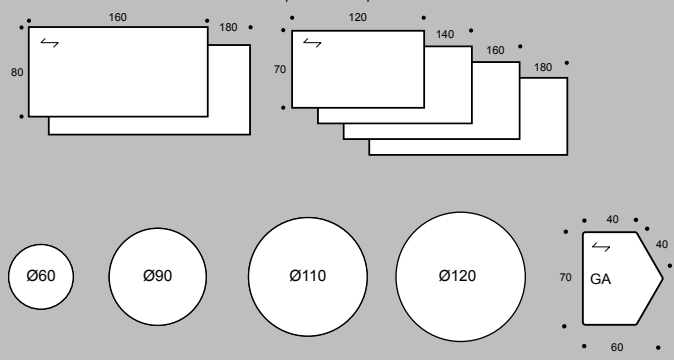

CAST EDGE COLOUR OPTIONS:

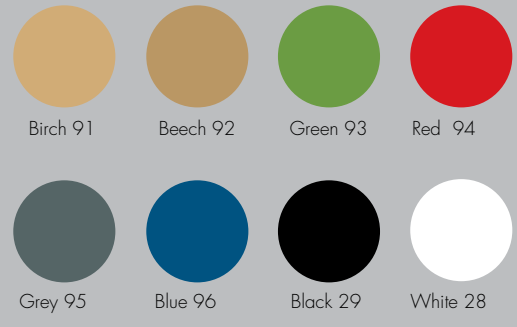

ROUND AND OVAL TOPS

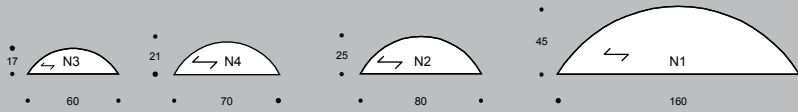
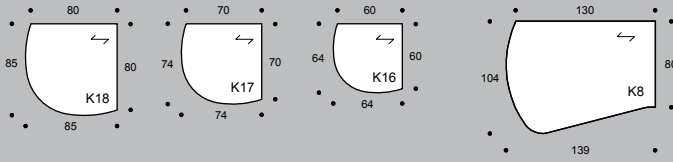
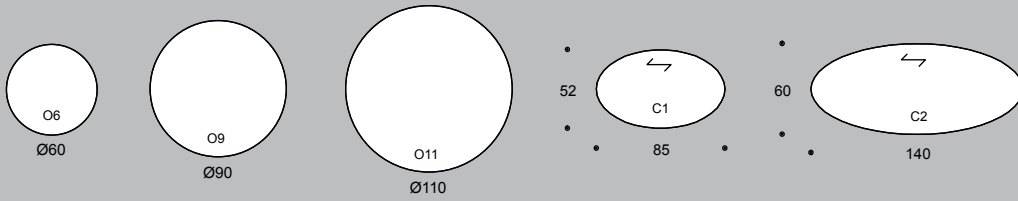

TOPS FOR CONFERENCE TABLES

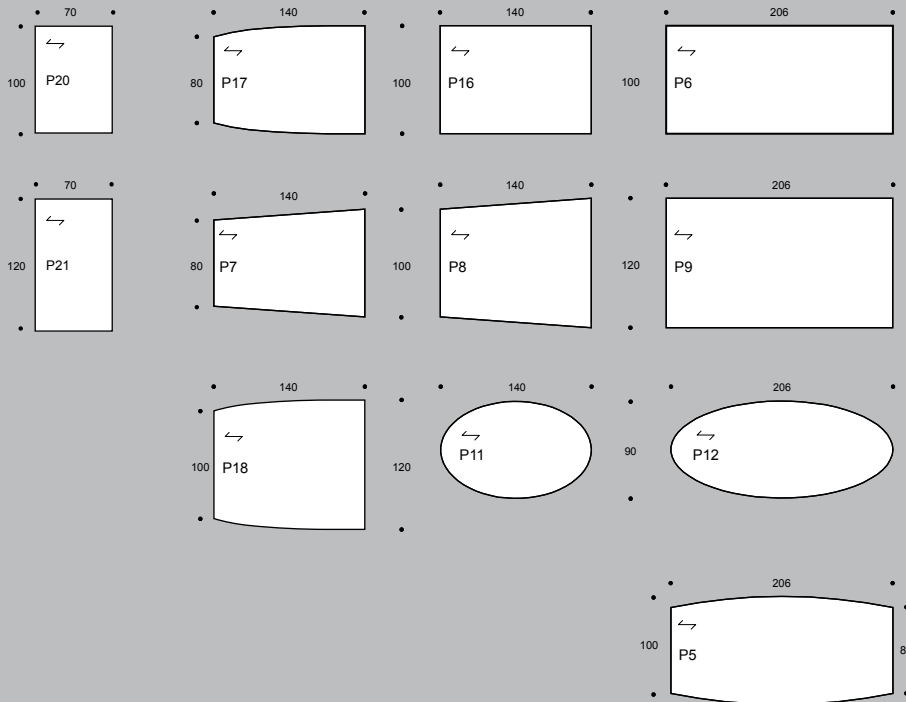

Top	birch	beech	oak	lam 230	lam 215
A4	•	•	•	•	•
A6	•	•	•	•	•
A8-20	•	•	•	•	•
B4	•	•	•	•	•
B6-16	•	•	•	•	•
C1	•	•	•	•	•
C2	•	•	•	•	•
C4	•	•	•	•	•
C6	•	•	•	•	•
C8	•	•	•	•	•
C10	•	•	•	•	•
C12-18	•	•	•	•	•
D12	•	•	•	•	•
Z10	•	•	•	•	•
Z12	•	•	•	•	•
WEA18	•	•	•	•	•
E12	•	•	•	•	•
WE16	•	•	•	•	•
WE18	•	•	•	•	•
WE20	•	•	•	•	•
WD16	•	•	•	•	•
WD18	•	•	•	•	•
WD20	•	•	•	•	•
EL16	•	•	•	•	•
EL18	•	•	•	•	•
EL20	•	•	•	•	•
J12	•	•	•	•	•
K8	•	•	•	•	•
K16	•	•	•	•	•
K17	•	•	•	•	•
K18	•	•	•	•	•
N1	•	•	•	•	•
N2	•	•	•	•	•
N3	•	•	•	•	•
N4	•	•	•	•	•
O6	•	•	•	•	•
O9	•	•	•	•	•
O11	•	•	•	•	•
P5	•	•	•	•	•
P6	•	•	•	•	•
P7	•	•	•	•	•
P8	•	•	•	•	•
P11	•	•	•	•	•
P12	•	•	•	•	•
P16	•	•	•	•	•
P17	•	•	•	•	•
P18	•	•	•	•	•
P19	•	•	•	•	•
P20	•	•	•	•	•
P21	•	•	•	•	•
Q8	•	•	•	•	•
Q18	•	•	•	•	•
U16	•	•	•	•	•
U18	•	•	•	•	•
U20	•	•	•	•	•
V6	•	•	•	•	•
V8	•	•	•	•	•
V10	•	•	•	•	•
V12	•	•	•	•	•





ISKU INTERIOR SUBSIDIARIES AND SALES OFFICES ABROAD

Isku Interior Oy export

Mukkulankatu 19
P.O.Box 240
FI-15101 LAHTI
Finland
tel. +358-29 086 3000
contact@isku.fi
www.isku.com

SWEDEN

Isku Inredningar AB/ Office Management

Skalholtsgatan 6-8
164 22 KISTA
Sweden
tel. +46-8-734 32 48
www.isku.com

NORWAY

**Isku Interiør AS/
Norengros**
Postboks 6714 Etterstad
N-0609 OSLO
Norway
tlf: +47-901 34 650
e-mail: firmapost@isku.no
www.isku.com

ESTONIA

Isku Mööbli AS
Pärnu Mnt. 139 f
EE-11317 TALLINN
Estonia
tel. +372-6 556 055
isku@isku.ee
www.isku.ee

LATVIA

Uab Isku Baldai Filiale
Brivibas str. 197
LV-1012 RIGA
Latvia
tel. +371 6779 8171
isku.riga@isku.lv
www.isku.lv

LITHUANIA

Isku Baldai UAB
P. Luksio gatve 21
LT-2600 VILNA
Lithuania
tel.+370-5 278 8751
isku.baldai@isku.lt
www.isku.lt

RUSSIA

Isku Interior M
B.Sergyevsky per. 10
107045 MOSCOW
Russia
+7-495 926 1531
contact@isku.fi
www.isku.ru

Isku Interior SP

Suomi Talo, office 108
B. Konushennaya str., 4-8
191186 ST.PETERSBURG
Russia
+7-812 448 1138
contact@isku.fi
www.isku.ru

Isku Interior Oy
Mukkulankatu 19, P.O.Box 240, 15101 Lahti
tel. +358 29 086 3000
www.isku.com



