

ISKU

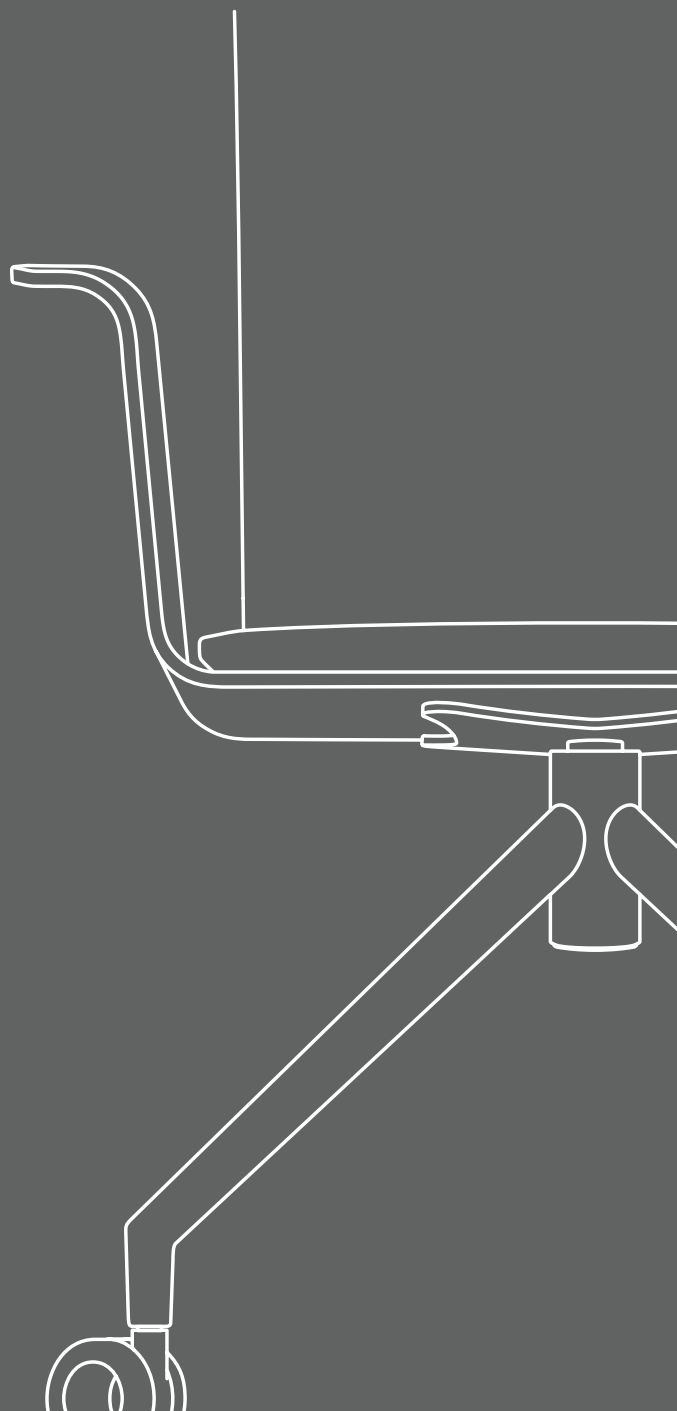

Working environment

Isku story	6
Design	8
Environment and responsibility	10
Active working	12
Antimicrobial surfaces	14
Customer segments	90
Control room concept	104
Services	106
Collection	112
Seating	114
Office chairs	140
Work desks	148
Tables	152
Storage	162
Dividers	172
Accessories and decor	178
Materials	190
Desk and table tops	194
Product index	196

Since 1928





Pure materials.
High quality.
Finnish design.
Always responsibly.



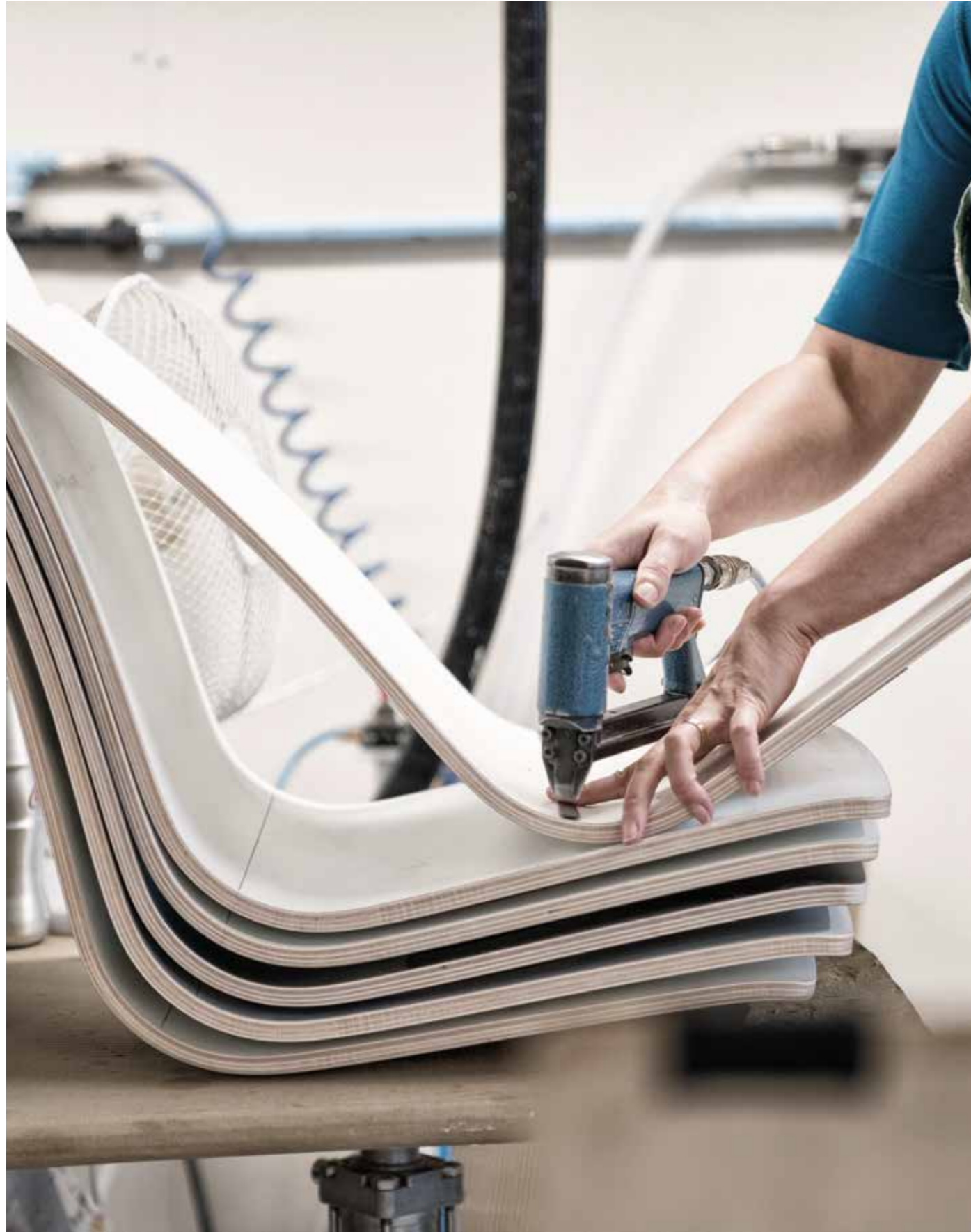

Unique Finnish know-how

Isku is a Finnish family business established in 1928. We design and manufacture furniture in Lahti, Finland.

Being a Finnish company is both a resource and source of pride. It is our operating principle to provide our customers with a sense of success at home, at school, at work, in hospital and care environments as well as in other public facilities. Our values - Inspiring, Finnish, Ready to listen and Evolving - guide our operations. We want to be the most distinguished and recommended service providing company of the interior design field to customers and employees alike.

We want to offer our customers the very best and fastest service. We operate responsibly every day and we respect customers, partners and personnel in everything we do. We are continuously developing our production, products and the competence of our personnel. This is how we generate new innovation.

We look for inspiration in the Finnish forests, pure raw materials and ecological manufacturing methods. All Isku products fulfil high quality and safety requirements. Every product in our collection has been tested in our testing laboratory. We collaborate with our international design network and closely follow the changes taking place around us. We want to be a pioneer. Being Finnish, functionality, minimalism and lightness form the basis of our design. All of Isku's interior design solutions have been designed in order to be able to adapt to many facilities according to different needs and to withstand the test of time. Our diverse collection allows innovation to surface and leaves room for creativity in all environments.

At the forefront of changing design

We at Isku stay alert; we listen to the environment and customer and keep up with the changes of the time. We are looking for new product ideas through many channels. We collaborate closely with architects and educational institutions on an international scale and our wide network of freelancers is actively involved in our product development. We organise international design competitions, collaborate closely with several educational institutions of the design field and the majority of new ideas and demands are created as the result of this collaboration. Our new Design Lab workshop enable quick experiments with models.

In order to honour the 100th anniversary of Finland's independence, we organised the Finland 100 furniture design competition, which was approved by the Prime Minister's Office as an official Finland 100 partner. Our goal was to discover furniture families suited for industrial manufacturing and sales. The competition categories were home, work environment, learning environment and care environment. We received over 130 innovative competition entries providing us a wide-ranging cross-section of the present state of design.

Our products are manufactured in Lahti, Finland. We are a pioneer within our field in terms of technology development and our new production lines are unique on the international market. We stand out from the competition by our high level of design and innovative technology. With the help of our production technology, our furniture can be manufactured ecologically and sustainably.

Our design values include being Finnish, functional, minimalist and light. We combine functionality with our service concept in order to make our furniture diverse, adaptable and, in terms of the design, light and practical that also supports well-being. Our furniture adapts according to the needs of the space, for example, from a teamwork room to more calm and individual solutions.

We emphasise ecological design from the very beginning of the design process and want to act responsibly honouring our environment. We have operated as the pioneer of Finnish design according to these principles since 1928.





Sustainable responsibility through the circular economy

Our responsible actions begin already at the design phase of a piece of furniture and continue all the way to its production and transport to the final destination. We have centralised our procurement to Finland and we purchase wood material only from forests maintained according to the principles of sustainable development. We ensure that the raw material used by our supplier chain comes from responsible sources and we encourage the use of local producers. We want to provide work to the Finns.

We are the only industrial actor in the furniture field in Finland that employs the tracking system for wood origin, PEFC (chain of custody). We know the origin of all the materials arriving at our plant. Our tracking system covers all the furniture in our standard collection. You can buy a sofa from us that has been manufactured with Finnish raw materials only.

We have set strict environmental requirements on the materials we use. We minimise the indoor-air emissions generated by our furniture, for example, by treating all surfaces with water-dilutable surface-treatment agents only. In order to guarantee good indoor-air

conditions, we carefully select the wood-based boards and use thermoformable Grada plywood with no added formaldehyde containing glue.

We invest in the circular economy thinking and go through the product life cycle from the designer's desk to a finished piece of furniture. We want to save energy and use any surplus material from the production of one product as the raw material for another product. This is, for example, how the Kivikko product family was created. In our testing laboratory, we test the durability and safety of our prototypes in the product development phase and make the necessary improvements.

We train our personnel in the Isku Academy to act responsibly and promote their development. We have also centralised all of our procurement. We are a responsible Finnish company going global.

Active working – work environment in changing times

At the workplace, an employee meets colleagues, develops personal skills and strengthens co-operation. A workstation no longer defines the working space; instead, the activity defines the place. Diverse meeting points are needed: silent rooms and various places for teamwork and projects. Creative encounters and relaxing need different spaces.

Digitalisation creates the preconditions for mobile working. A workstation can be selected according to the nature of the task at hand. Current digital solutions can be used to set up virtual meetings anywhere. Even time is no longer a restriction; work can be done irrespective of time and place. A workstation can be situated at home, in a café, on a train or at the beach. Ways of working are constantly developing.

New ways of working and work environments adapting to people's needs offer the means for operational rearrangement and changing the corporate culture. The role of occupational well-being is increasing. The well-being of the employees' increases productivity and the efficient use of space is no longer the only factor in space planning.

The starting points for designing a work environment are the users' needs and the adaptability of the environment for different work tasks now and in the future.

Extensive needs assessment before designing and implementing the facilities create an opportunity to develop and emphasise the strengths in the customer's corporate culture and to improve the existing operating models, or to create completely new tools and ways of working. The personnel are committed to the change by involving themselves in the development process. The internal communication of the company improves while increasing understanding between different user groups.

We at Isku believe in the importance of the work environment development. The implementation of a comfortable and motivating environment is a broad ensemble. It also involves design, collaboration, involvement, management, technology, production and especially service. We create concepts where the phases of design and implementation are equally important as the guidance provided at the beginning of use. We focus on creating workplaces of the future where comfort and functionality play key roles.





For healthier working environment

We spend a lot of time in various shared premises at offices, public spaces, schools, day-care centres and care facilities, and come into contact with surfaces and furniture. In such places, contagions spread easily. We shoulder our responsibility for the best possible cleanliness of work environments. The Isku Health collection is an effective new solution for preventing the growth and transmission of microbes.

Your business premises are an important part of your identity and brand. With the tested and researched materials and solutions of our collection, we can build and furnish cleaner facilities using materials that eliminate the growth of microbes. And increase your well-being. The entire Isku Health collection is available for offices, schools and public premises.





*Suomi
Finland*
100

NEW

Big Hug
Design Mika Tolvanen

Winner
Finland 100 design competition

Big Hug

Design Mika Tolvanen

3726

*Suomi
Finland*
100

Big Hug is the winner of Isku's Finland 100 furniture design competition. Living up to its name, Big Hug is an open easy chair for comfortable times. The strong texture of the soft fabric contributes to a relaxed impression. Big Hug is completely upholstered, and the seat frame is made of thermoformable Grada wood material. The legs are made of chrome-plated or painted steel pipe.



Mika Tolvanen

The design work began with a large number of different ideas and sketches. I wanted to create an easy chair that would be as comfortable as possible and inviting thanks to its openness. I went through my ideas and sketches and selected those best suited to this purpose. This is how Big Hug came about.





Tutto

Design Mikko Laakkonen

3240, 3241, 3244

*Suomi
Finland*
100



Tutto is a chair family that can be adapted to a multitude of applications. The chair features a single seat section that is available in pressed wood or upholstered. A low or high backrest, wooden or upholstered, is fastened to the seat section. There are four different leg options available for the chair. With the low backrest and short legs, Tutto serves as a general-purpose chair. The high backrest turns Tutto into a distinguished conference chair. With just the seat section and long legs, Tutto serves as a bar stool. The various elements can be used to form an almost unlimited number of different combinations, each with their own function.



Mikko Laakkonen

I wanted to design a chair that would provide interior architects and architects with a versatile tool for furnishing spaces. The product family consists of a single pressed seat with which various backrests and legs can be combined. I lived in Rome with my family when I designed the chair. For this reason, its working title in the Finland 100 design competition was Cellule, which is Italian for "cell". The purpose of this cell is to divide into so many variations that it provides almost everything you look for in a chair.

Duo Lounge

Design Antti Olin

3291, 3293, 3295

The Duo chair family has grown with the introduction of the new Duo Lounge chairs. These low-slung seats are ideal for many kinds of spaces and situations. The Duo Lounge chair has the same elegant lines as the Duo conference chairs, only with a wider frame and rounder edges. Duo Lounge creates a casual and elegant space, and its multiple base options make it a great fit for many different situations and environments.



Antti Olin

The starting point of the design was relaxation and softness. That is how the Lounge version of the Duo conference chair came to be. Relaxation was achieved by tilting the sitting angle further back and lowering the seat. The Duo seat and armrests are at the core of all the design work, and the three base options allow the chair to be used in multiple different spaces.





Amphi

Design Henri Halla-aho

3754

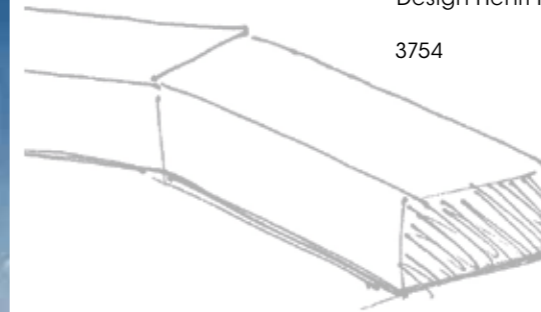

An amphitheatre is a traditional place for meetings and performances. Amphi challenges architects, interior designers and users to let their imagination and creativity run free, playing with the modules. The seats of various sizes constitute a theatre where users both small and tall will find a natural seat height. The pieces are equipped with castors as standard, so they can easily be moved around. Amphi may also be equipped with plastic or felt pads instead of castors. Amphi is made of chip foam, a material which is recycled foam plastic. The dense and soft material also improves the acoustics of the space.



Henri Halla-aho

Amphi stemmed from the need to design a piece of furniture for open learning and work environments, providing a natural place for meetings, discussions and interaction. The design work was based on a strong image of a traditional amphitheatre and the people gathering there.

Ark

Design Henri Halla-aho

2700-

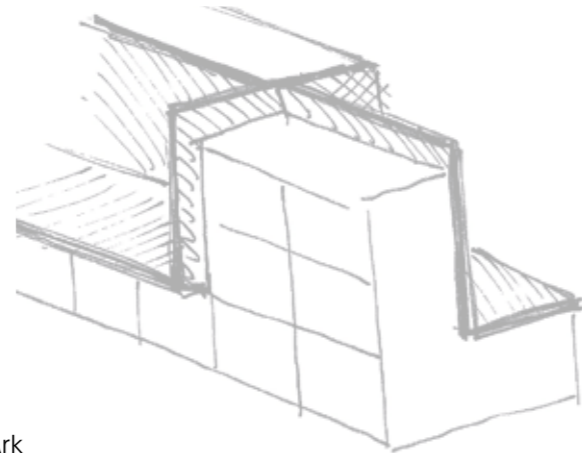

Shared spaces come to life with Ark storage modules, which can be used to create stimulating environments. The Ark system features seats, desks and one- and two-sided storage cabinets. Electrical solutions have been integrated into the cabinets, and devices can be locked in them for charging. Different locking options are available: a key lock, mechanical number lock and electronic lock. Various materials and colours can be used to construct a wide variety of landscapes and atmospheres. The soft materials improve the acoustics, and the usability of the modules is increased by castors.



Henri Halla-aho

I wanted to design a scenic system that would be more than just a series of cabinets. Ark consists of various modules that can be used diversely to create inventive solutions for storage, work or spending time together.



NEW





Vakio

Design Juri Karinen

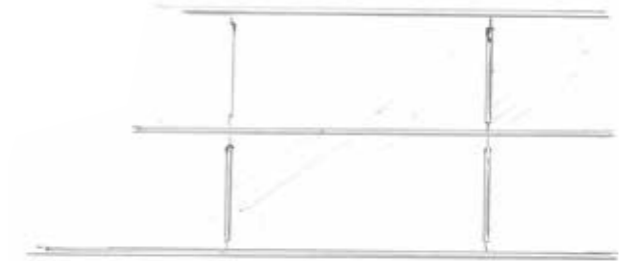

Vakio is a universal shelf system. It fits spaces where the boundary between public and home furniture is dissolving. The materials of the Vakio shelf provide the technical solution themselves. The shelf is made of birch plywood with grooves in which the acrylic doors slide easily without any fittings or runners. The metal frame is the backbone of the shelf and provides the bookends. Thanks to its simple modular structure, the shelf can be installed freely in both width and height. The shelf does not need to be in the traditional bookshelf format; it may be composed from the users' creative perspective and according to their individual needs.



Juri Karinen

The Vakio shelf was formed when I learned about an existing mounting system, which became the backbone of the design. I designed Vakio in a straightforward manner, eliminating everything excessive. My aim was to come up with a practical solution based on the quality of the materials. I wanted to create a simple, aesthetically sound, high-quality, universal system suiting domestic and public spaces alike.



Rudolf
Design Mikko Paakkanen



Rudolf
Design Mikko Paakkanen

**Lightness**

Design Samuli Naamanka

**Metro**

Design Kurt Hvitj 



Versio
Design Tapio Anttila

**Signum**

Design Raimo Räsänen



Duo
Design Antti Olin





**Geneve Plus Pro**

Design Nea Vikström



Syke

Design Mikko Laakkonen



Inkoo Pro High
Design Ilari Jääskeläinen



Tere
Design Antti Olin

**Kaari**

Design Henri Halla-aho



Inkoo Pro
Design Ilari Jääskeläinen

**Free**

Design Ilari Jääskeläinen







Still
Design Antti Olin



Step+
Design Juha Lähti





















Our customer segments





School

Isku Active Learning is a concept and an entity. We develop, design and implement versatile learning environments and learning landscape solutions together with the customer and the best experts. We are strongly involved in the everyday life of the school and contribute to the continuous development of the operating environment.

Interaction, co-operation and versatile working promote the well-being and learning of the community. The Isku Digital Learning Lab concept is an exceptionally active entity; its implementing elements include the spatial and technical design, equipment, various pieces of furniture and the user experience. An Isku Digital Learning Lab can be situated flexibly on new or existing premises, taking advantage of underutilised corridors or lobbies. We promote different ways of leveraging the opportunities created by digitalisation.





Health

In hospitals and healthcare facilities, it is important to have flexible, adjustable and efficient facilities. There are client and treatment rooms as well as staff facilities planned for different kinds of work needs. In shared facilities, various infections spread more easily, and it becomes vital to break and prevent the chain of infection. Studies show that new materials and furniture solutions can reduce the amount of infections transmitted at hospitals by up to 60%*.

Isku Health is the world's first furniture collection that reduces the spreading of infections. Isku's innovation is based on copper and silver technology on surfaces as well as in fabrics and upholstery, which actively prevent infection. Our range offers a safe and pleasant environment for everyone, taking special needs into account. Our solutions comprise sustainable, antimicrobial, adjustable, serviceable and cleanable furniture. We have given special consideration in our products and materials to the requirements set by the operating environment. Isku's furniture for hospital and healthcare environments are Finnish design. In addition to being functional and safe, our solutions also feel and look good.



In co-operation with



* A study funded by the United States Department of Defense observed a 58% decrease in the risk of patients in intensive care of getting infected in a hospital environment when the most frequently touched surfaces in their rooms were replaced with antimicrobial copper.

Care Collection

The furniture in Isku Care Collection creates a sense of home in care environments. We have developed the furniture over the years interactively with care providers and care receivers. For the residents of the service home, the living facilities feel pleasant, safe and like home. Individual solutions and revitalising environments create health, well-being and quality of life.

Shared premises are built according to the needs of the residents, staff and visitors. The facilities, solutions and furniture are easy to modify, which improves cost-efficiency. The Isku Care Collection offers versatile possibilities for sensory stimulation and variety. We want to create spaces to encourage activities that support well-being.



Home

We want to offer you the best conditions for working at home and at the workplace. We make ergonomics cosy and cosiness ergonomic. Give ideas and innovation wings!

As work culture changes, so does workplace furniture. You can move between several workstations – wireless tools move with you to sofas, beanbag chairs and beds. Offices have increasingly more comfortable furniture and soft surfaces.

Furniture from Isku's home collection is also available for public premises, which helps keep your work facilities cosy and increases comfort at work.

We can also use furniture from Isku's home collection to build a cosy and attractive workspace on public premises.

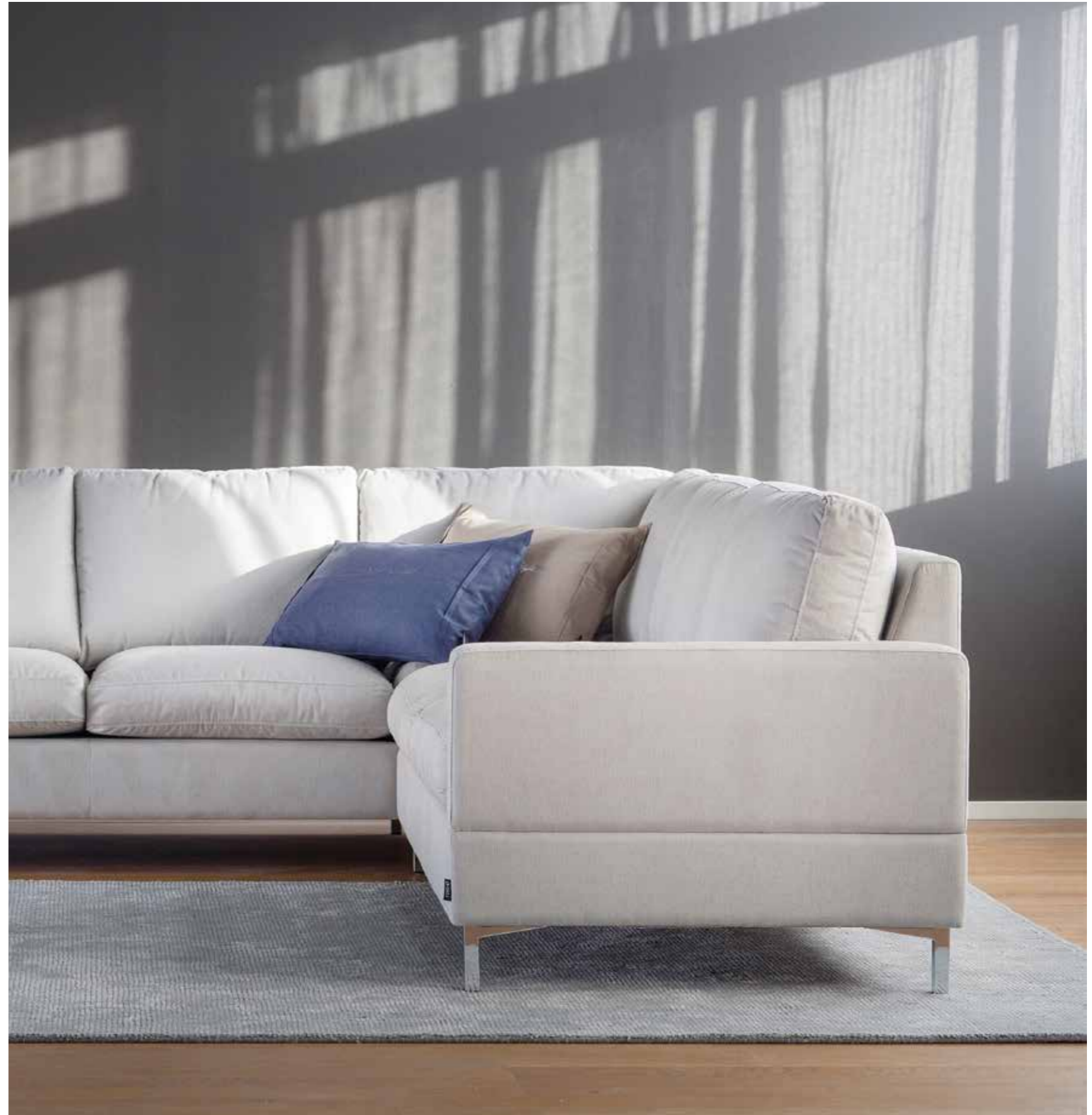



Concepts

All of our core operations are produced within our organisation. Thanks to this, we can deliver customised solutions quickly and meet your exact needs. Our close co-operation with the customer, entrepreneurial and creative atmosphere, environmentally-friendly materials and Lahti-based production create the preconditions for manufacturing concept furniture.

Our technical designers design the solution in co-operation with the customer. We test the product's safety and quality at Isku's test laboratory, thereby ensuring the suitability of customised products for our clients.

Control rooms

The Isku Control room concept is always designed and implemented in collaboration with the user and designers. Isku has a test desk available for fine tuning customer's ideas together with the designers in order to take into account the special needs of the set-up. Isku collaborates with well-known actors in the field making sure that the best, modern components and materials are used according to the standards.

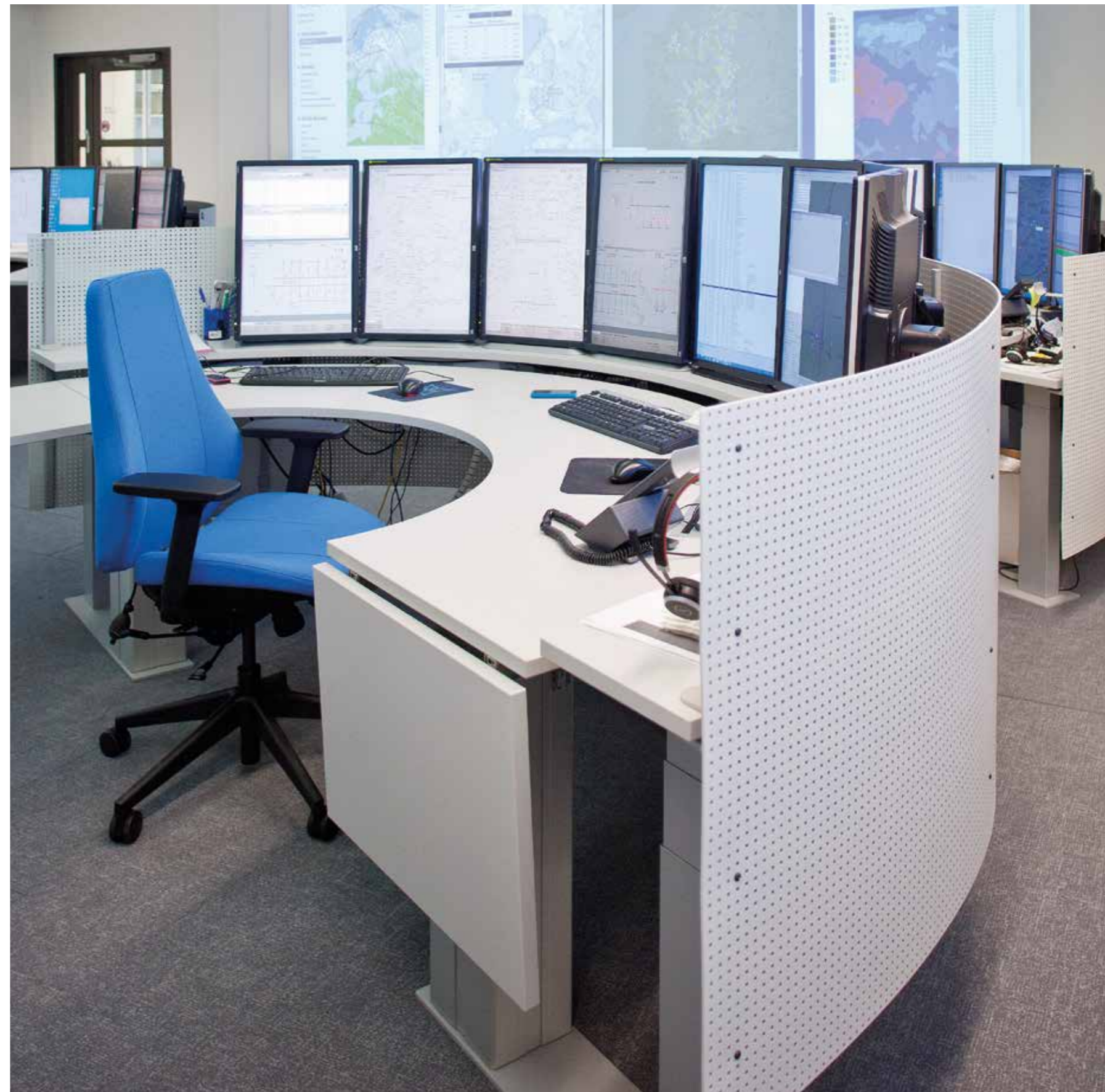

Isku Control room desk concept

The control room and operations desk is a customised 24/7 desk concept that can be easily adapted for the needs of the customer.

The desk concept is a package that is designed for different kinds of workstation applications and facilities. User comfort, ergonomics, efficiency and safety of use are realised in round the clock use of the control room concept.

The control room desk concept is easy to customise and implement to meet the customer's needs in terms of form as well as features.

Our service concept is founded on the design service that helps find the best and most suitable package for the intended use.

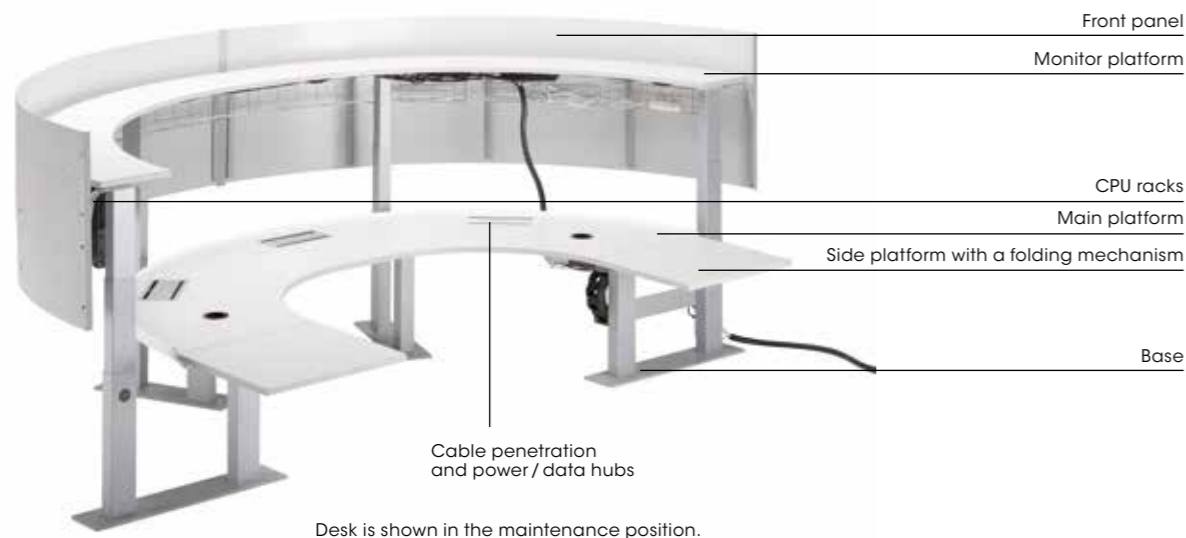

Control room desk features

- Extremely strong frame structure
- Stepless adjustment of both levels
- Best ergonomics for sitting and standing
- Modular frame structure
- Vertical or horizontal monitor arrangement
- Cabling and electrical wiring can be hidden
- Wide range of optional accessories
- Easy to service



The CPU holder is designed for easy maintenance and the replacement of units.



The control room desk's control panel can be chosen to best meet users' needs. A control panel is shown with three memory locations and height control as well as a built-in pen holder.



Independent electronic adjustment of the main platform and monitor platform. Adjustment range 65 cm (59.5–124.5 cm).



The power hubs can be equipped based on customer preferences. Various customer-specific accessories can be easily arranged.



The cables running in the desk structures are gathered and bundled away neatly.

KAB Control room chairs



Standard features

- Strong robot-welded steel frame
- Wear-proof upholstery
- Adjustable leather headrest with two joints (not Navigator or K1 Premium)
- Fully tip-up armrests (adjustment of armrest's front edge height / inclination)
- Quick-adjustment of backrest inclination
- Air lumbar support
- Lockable rocking mechanism with resistance adjustment
- Sitting height 46–56 cm
- Soft double castors
- Aluminium base
- User-specific warranty limit up to 200 kg

Services

Here at Isku, we see our products as a part of a larger whole – our service. We create successful experiences for our customers. We are a reliable partner for our customers, from the design of working and learning environments to consulting, design and implementation as well as follow-ups and maintenance. The customer's individual wishes and needs define Isku's role at the different phases of modification projects.

A work environment development project is not just a modification of premises – it is also a unique opportunity to build a new work culture and an investment into occupational well-being. Encouraging personnel to participate plays a central role in the modification. We offer interior design by professionals in the field. We employ interior architects and designers.

We also provide full recycling services for removing your old furniture and recycling them. Serviceable furniture is restored and sold on our second-hand market. Unserviceable old furniture is sorted into metal, wood and plastic parts for further recycling.

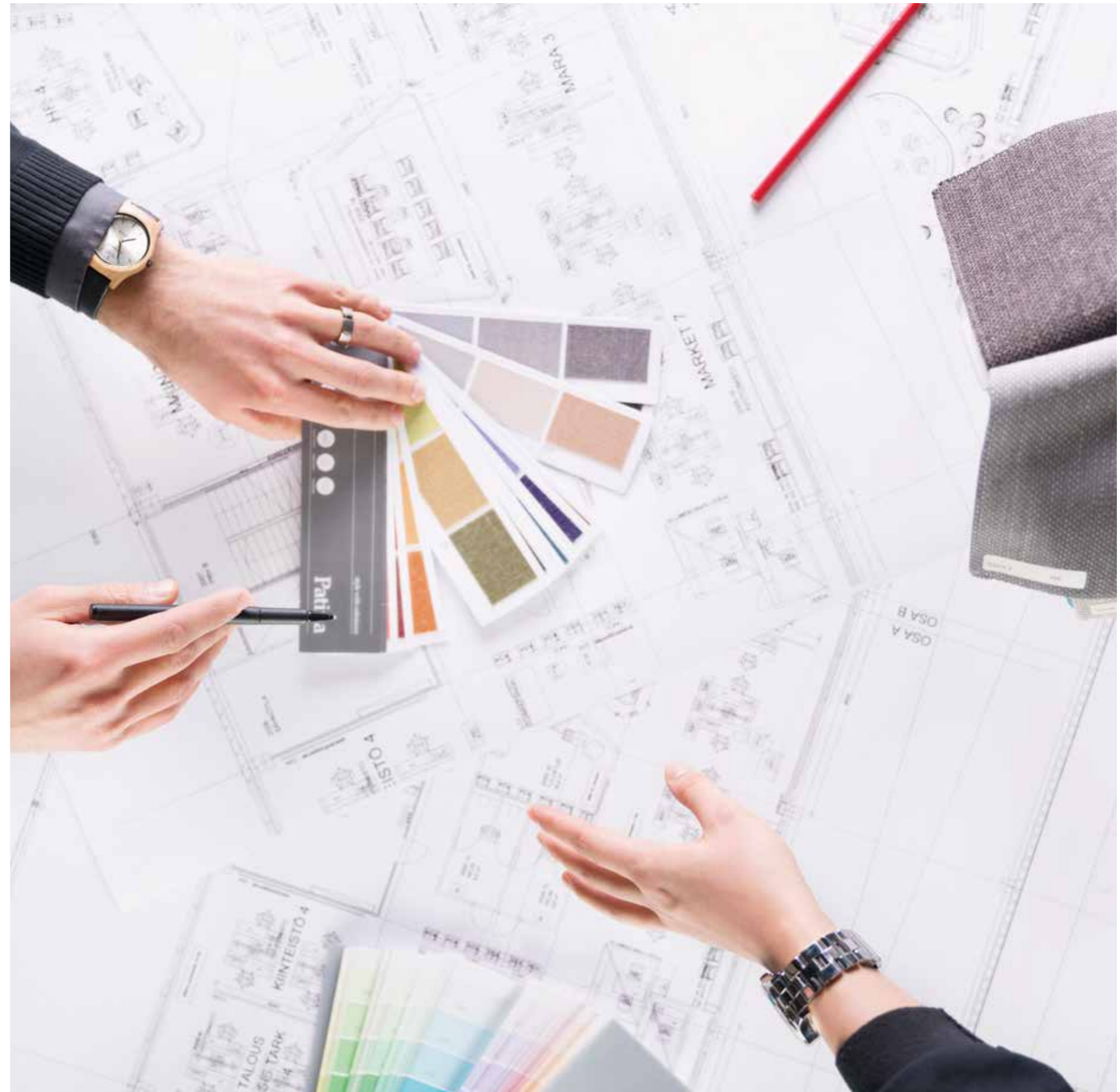

Our services



Learning environment development - Active Learning

A desirable learning landscape is a functional, participatory and inspiring synthesis of the physical, social and digital environments. The development work creates the foundation for a learning environment that supports interaction, is adaptable and facilitates the appropriate implementation of the curriculum.



Project management

Comprehensive project management from design to implementation. The project plan includes jointly drawn-up budgets, objectives and schedules, based on which the project is advanced in a coordinated and cost-efficient manner.



Interior design

User-oriented interior design creates comfortable facilities that meet the customer's needs and support work in many different ways. The scope of the design service can be scaled from tiny details to a comprehensive facilities plan.



ISKU Booking

Application-based facilities-booking system for easier booking and management of facilities in an activity based office. Thanks to its diverse and intuitive features, the system can be customised based on the customer's operations and needs.



Concept furniture and customisation

Decades of furniture manufacturing experience and professional product design enable customer-specific products and customisation.



Furniture rental and leasing

Instead of a large one-time investment, products and services can be purchased through financing – a flexible way to free the company's capital for more productive purposes.



Assembly and transport

Furniture transport and installation as well as diverse alteration work are done professionally and efficiently on the agreed-upon schedule. The service can be made to include more extensive protection, workstation wiring and making everything ready for use.



Removal service

Comprehensive and high-quality removal planning and implementation ranging from furniture installation to personal moves. The service package includes a designated supervisor, trained in-house movers as well as transport equipment and supplies customised for removals.



Maintenance service

The comprehensive furniture maintenance service includes a condition survey along with the necessary maintenance and repair work and spare parts. Regular maintenance and a maintenance plan help reduce products' carbon footprint and increase their service life.

Avec

Isku Avec is a complete collection of high-quality office and design furniture that represents an extensive cross-section of modern furniture design. In addition to Isku's domestic collection, we offer our customers the Isku Avec collection, which consists of furniture from well-known design houses.



Collection

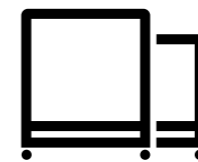



Seating



Rudolf

Design Mikko Paakkanen



3200

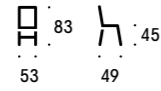

3204

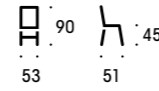

3201

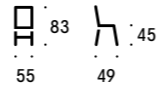

3205

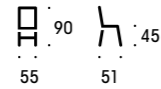

3208

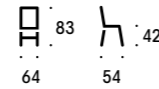

3201 Raised

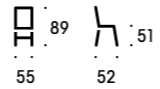

3209

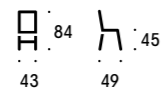

3209

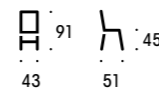

3202

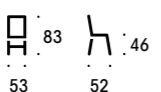

3206

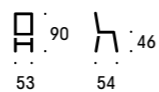

3203

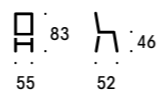

3200

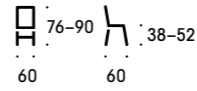

3205

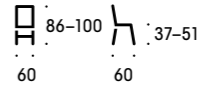

3210

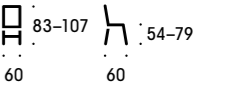

3210

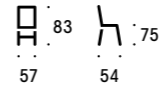

3210

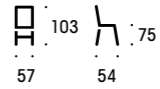

3210

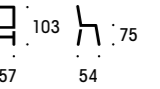

3209

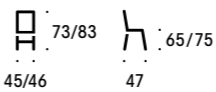

3209

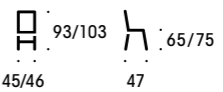

3209

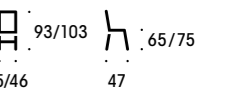

3211

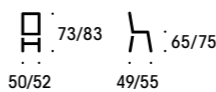

3211

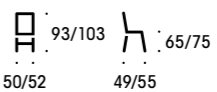

3211

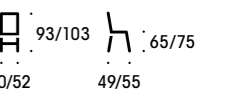

Signum

Design Raimo Räsänen



3110



3111



3113



3114



3740



3741

**Minus**

Design Tapio Anttila



3195



3199



3199



3193



3194



3195

**Logo**

Design Raimo Räsänen



3150



3151



3151 Raised



3170



3727

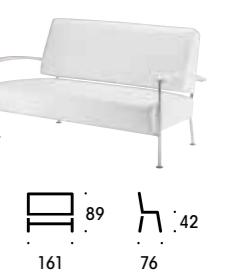

3727

**Matti**

Design Juha Lähti



3160



3160



3160

**Matti chair trolley**

2954



Versio

Design Tapio Anttila



3176



3177



3178



3180

**PRO 6**

Design Konstantin Grcic



29860



29861



29862



29863



Available with Pro-Matic 3D seat mechanism

Tuoli 50

Design Kurt Hvitstjör



4750



4750



4750

**Lightness**

Design Samuli Naamanka



3282 C4



3280 B



3280 B

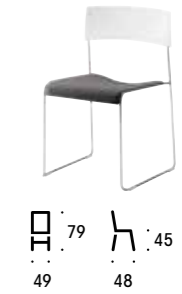

3280 B

**Lightness chair trolley**

3297

**Taiko**

29640



29640



29640



Duo

Design Antti Olin



Limited upholstery options

3272



3274



3273



3275



3275

**Duo Lounge**

Design Antti Olin



Limited upholstery options

3291



3293



3295

**Metro**

Design Kurt Hvijsjö



412



402



422

**Big Hug**

Design Mika Tolvanen



Limited upholstery options

3726



Suomi
Finland
100

Concorde

Design Tapani Laukkanen



4901

**Organo**

Design Raimo Räsänen



3730

**Cubio**

Design Tapani Laukkanen



4900



4900



4900



Sera

Design Raimo Räsänen



3106

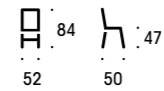

3106

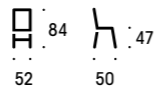

3107

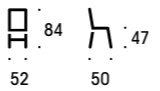
**Alias**

Design Raimo Räsänen



3184

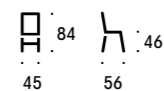

3186

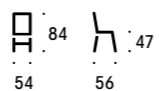

3186 Raised

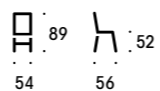

3703

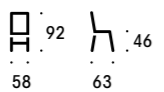

3704

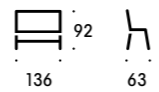
**Aura**

3148

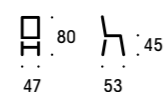

3149

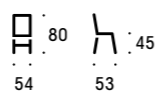

3148

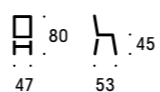
**Aino Pro**

3146

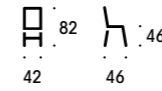

3146

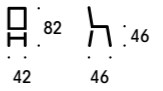

3146

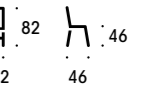
**Roope**

Design Ilari Jääskeläinen



33540

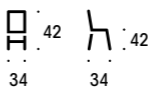

33540

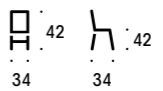

33540

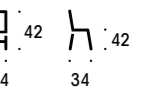
**IKI**

Design Ilari Jääskeläinen



5200

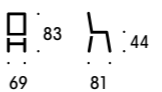

5200

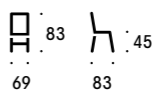

5200

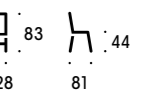
See the extensive IKI product family at www.isku.com

Tere

Design Antti Olin



3738

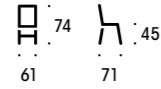

3738

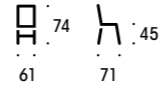

+ Writing pad

3738

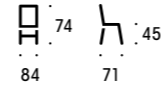

3738

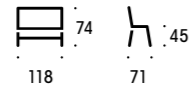

3738

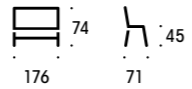

3738

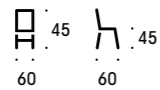

3738

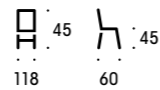

3738

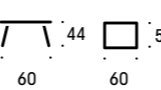
**Dyyni**

Design Tapio Anttila



3732

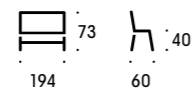

3732

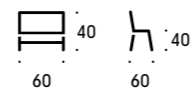

3732

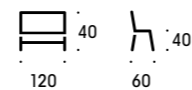
**Sigur**

Saara Renvall



3744

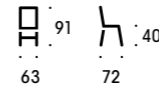

3744

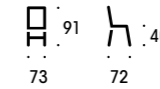

3744

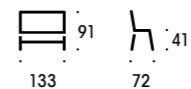

3744

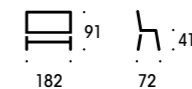

3744

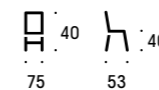
**Sigur sofa table**

Design Saara Renvall



3745



3745



3745

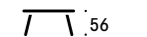

Syke

Design Mikko Laakkonen



3725

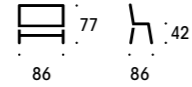

3725

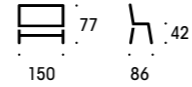

3725 Sofa table

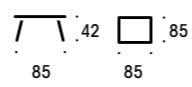

3725

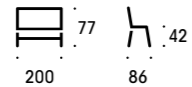

3725

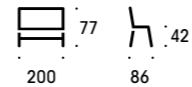

3725

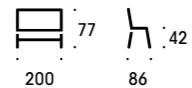

Geneve Plus Pro

Design Nea Vikström



3712

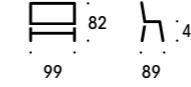

With armrest A

3712

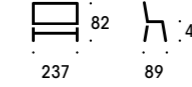

With armrest B

3712

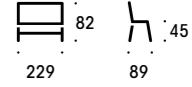

With armrest A

3712

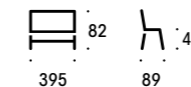

With end board

3712

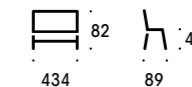

With armrest B

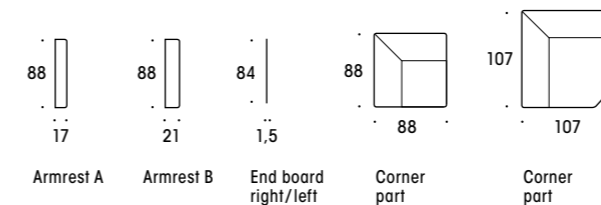
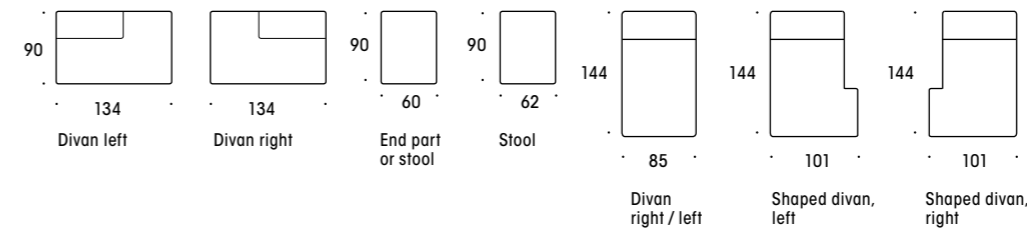
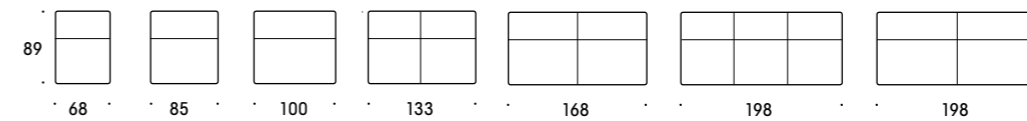

Module combination examples

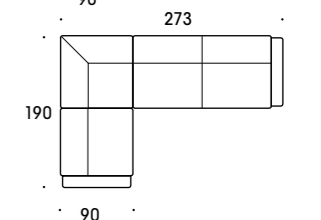
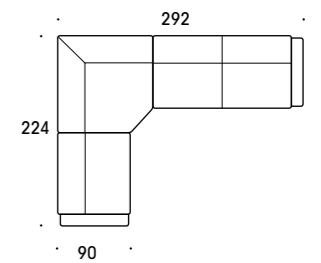

Inkoo Pro High

Design Ilari Jääskeläinen



3723 1 ½



3723 2 ½



Inkoo Pro

Design Ilari Jääskeläinen



3722 1 ½



3722 2 ½



3722 3



3722

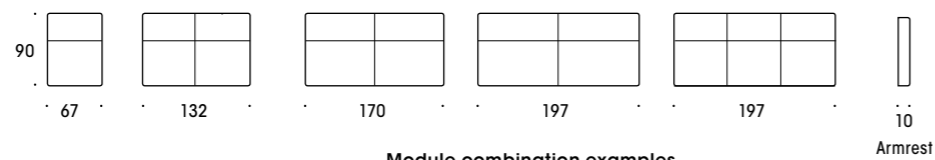

Module combination examples

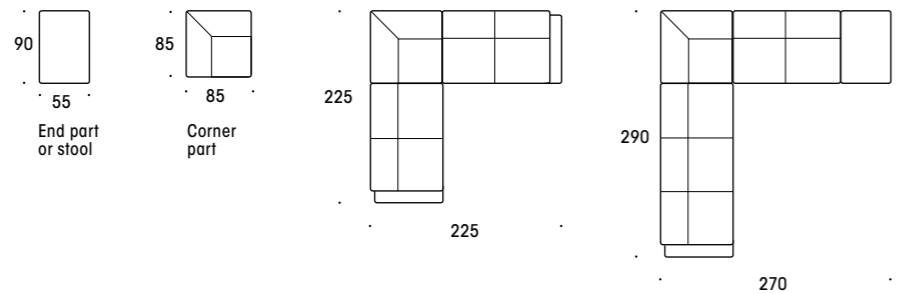

Kaari

Design Henri Halla-aho



3711

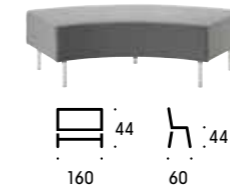

3711

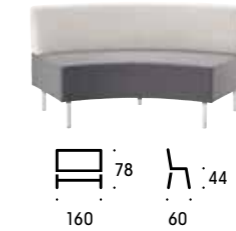

3711



3711

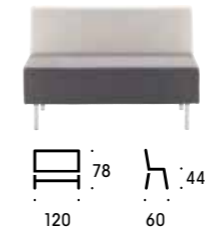

Bag and clothes hook



Drawing board
W 48, H 56
W 113, H 89

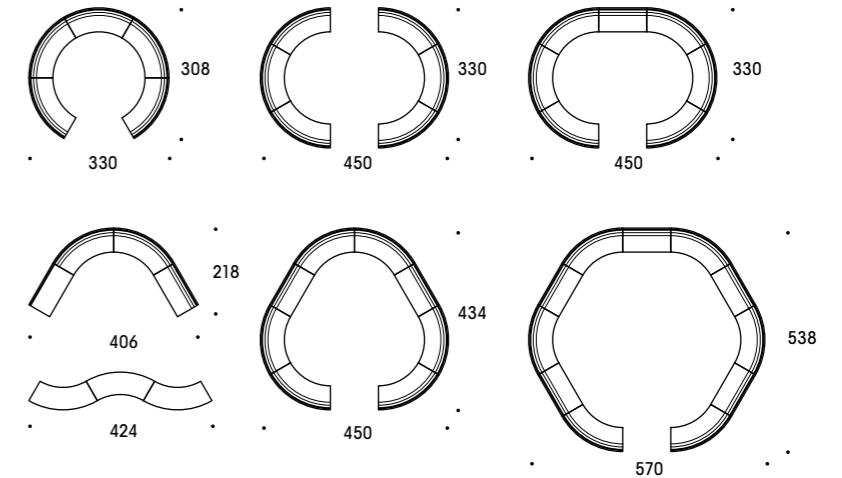

Kivikko

Design Henri Halla-aho



3748



Height 26 cm

3748



Height 40 cm

3748



Height 54 cm

3749



Table top + upholstered plinth

3749



Upholstered plinth



3753

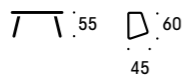

3753

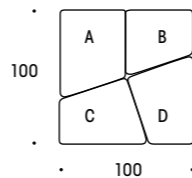
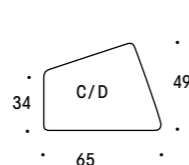
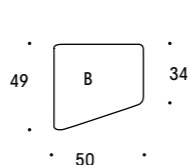
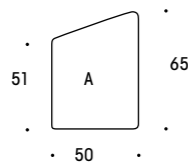
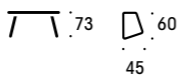

Amphi

Design Henri Halla-aho



3754



Height 55 cm

3754



Height 41 cm

3754



Height 27 cm

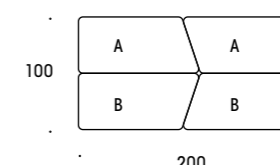
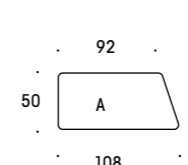

Mukula

Design Kaija Aalto



The safety distance between a cardiac pacemaker and the permanent magnet of a Mukula seat is 10 cm.

3747-550

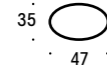

Height 7 cm

3747-502



Height 16 cm

3747-500

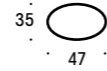

Height 16 cm

3747-506



Height 16 cm

3747-504



Height 16 cm

3747-602

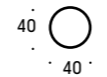

Height 23 cm

3747-600

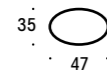

Height 23 cm

3747-510 Mukula wall element



W84 × D5 × H160
Shown in the image: three wall elements

Giant DonutDesign Ivar Gestranus
& Kevin Lahtinen

29884

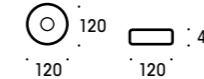
**The Box Lounger**Design Ivar Gestranus
& Kevin Lahtinen

29895

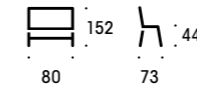

29895

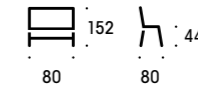

29895

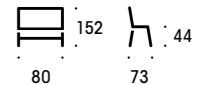

Time

Design Ilari Jääskeläinen



3540

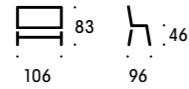

With armrest A

3540

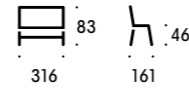

With armrest A

3540

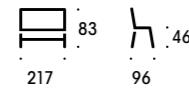

With armrest A

3540

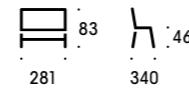

With armrest B

Time and Free sofa modules

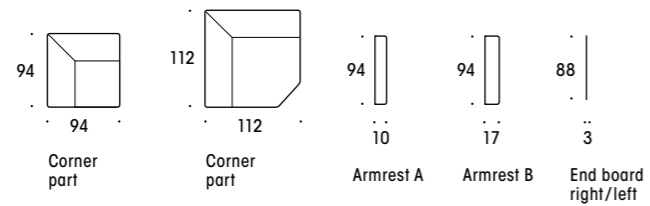
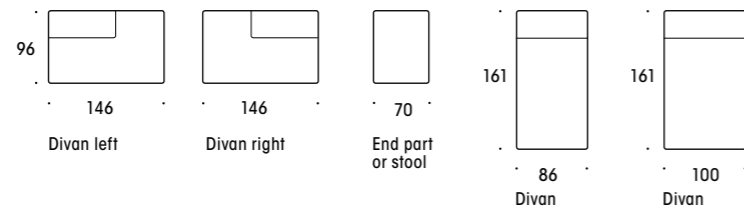
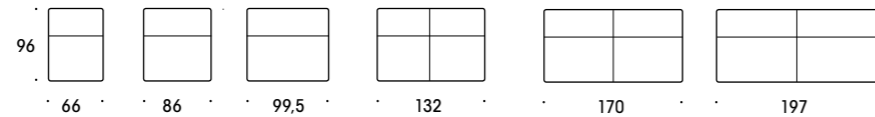

Free

Design Ilari Jääskeläinen



3541

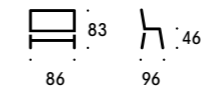

With armrest A

3541

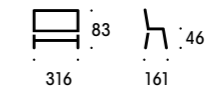

With armrest A

3541

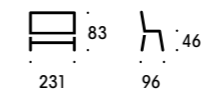

With armrest B

3541

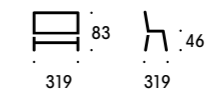

With armrest A

Time and Free module combination examples

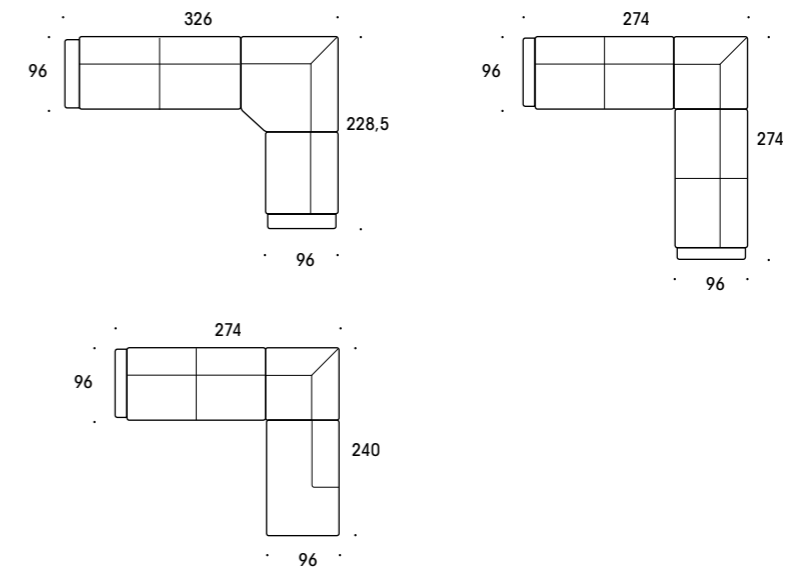

Casa

Design Ilari Jääskeläinen



3542

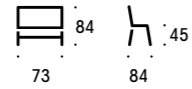

With armrest A

3542

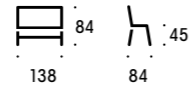

With armrest A

3542

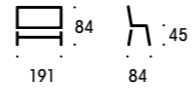

With armrest A

3542

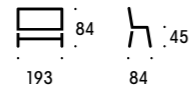

With armrest A

3542

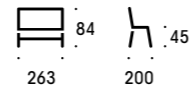

With armrest B

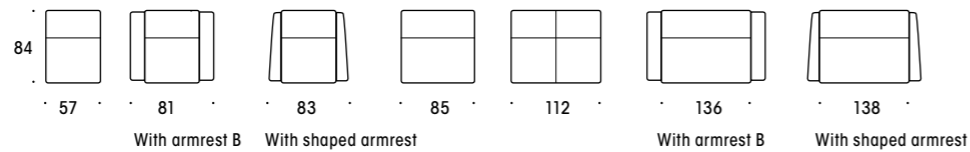

With armrest B

With shaped armrest

With armrest B

With shaped armrest

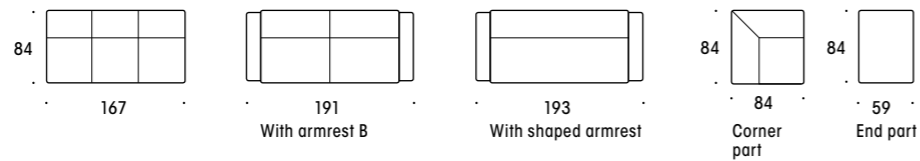

With armrest B

With shaped armrest

Corner part

End part

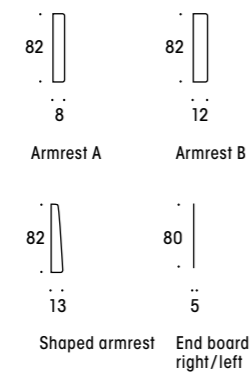

Armrest A

Armrest B

Shaped armrest

End board right/left

Module combination examples

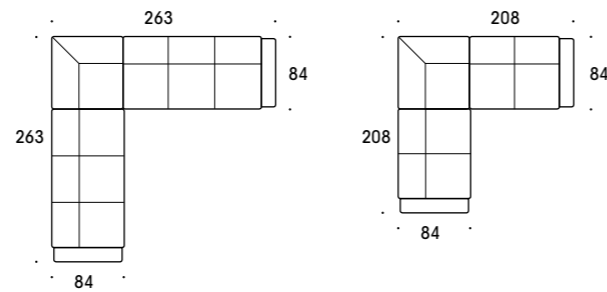

Diva

Design Ilari Jääskeläinen



3538

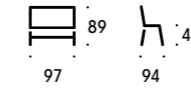

3538

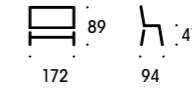

3538

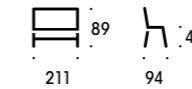

3538

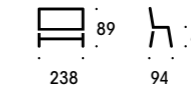

238

94



Office chairs



Still

Design Antti Olin



Still office chairs can be customised using various combinations of components.

3062 Still S2 28



Armrests soft 3D 360° ALU

3062 Still S2 29AN

Armrests soft 3D 360°
Mesh headrest

3061 Still S1AS 28



Conference chair armrests

3061 Still S1AS 29A



Conference chair armrests ALU

3061 Still S1AS 26C



Armrests soft 3D ±15°

3058 Still Light S1 22



Still Light armrests hard 2D

3060 S1AS 21 JR

**Still Meeting**

3055



3055



3054

**Step+**

Design Juha Lähti



Step+ office chairs can be customised using various combinations of components.

3070 Step+ 22



3070 Step+ 2s3



Armrests 3D 360° black

3070 Step+ 24N

Armrests 3D 360° black
Fabric headrest

3070 Step+ 3s6



Armrests 3D 360° ALU

3070 Step+ 37N

Armrests 3D 360° ALU
Leather headrest

KAB Control room seating

29705 Director



29706 Executive



29708 K4 Premium



29704 Navigator



29707 K1 Premium

**Salli saddle chair**

29701 Classic

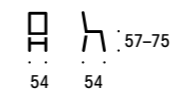

29701 SwingFit

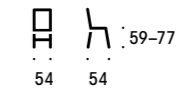

29701 Swing

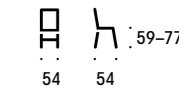

29701 Twin

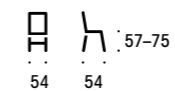

29701 Multiadjuster

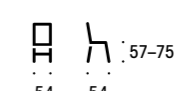

29701 Light

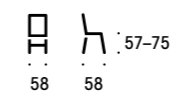

29701 Light Tilt

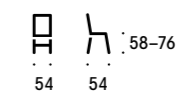

29701 Light Swing

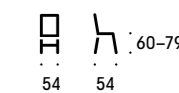

ILOA seat

Design Jonas Hakaniemi



29900 ILOA

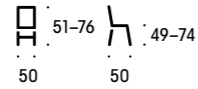

29901 ILOA+



29902 ILOA One

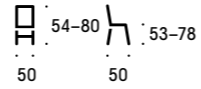

29904 ILOA Joy

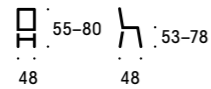

29903 ILOA Smile

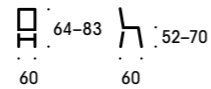

29908 ILOA Smile Bar

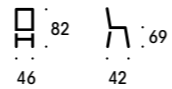

29905 ILOA Bar

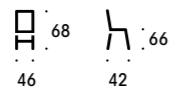

29906 ILOA+ Bar

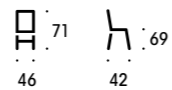

29907 ILOA One Bar

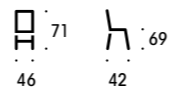

29909 ILOA Joy Bar

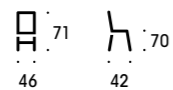
**3016 office chair**

Design Juha Lähti



3016 M

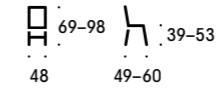

3016 M JR

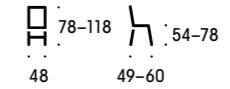
**Muvman**

29735

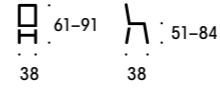

29735

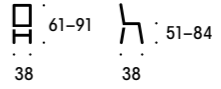

29735

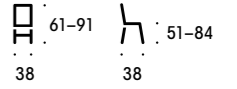
**Ongo**

29736 Free active sitting seat

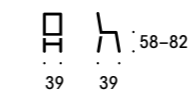

29736 Balance board

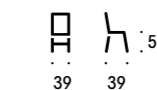



Work desks



Isku Easy T EL

Electrically adjustable table



Once assembled all cables are easily hidden in ducts within the frame – again, no use of tools or clips required.

2061



Isku Style T EL

Electrically adjustable table



2061



2061



2063



Isku Classic T EL

Electrically adjustable table



2061



Matrix T manual

Manually adjustable table



2056



2056



Matrix I

Manually adjustable table



2057



2058 Tall



Stone

Design design Vertti Kivi & Co



2840 Work station

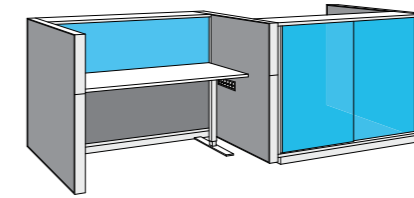

2810 Sliding door cabinet

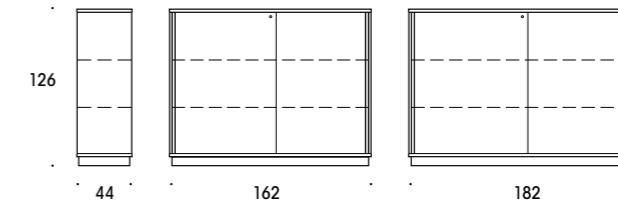

2810 Storage tower

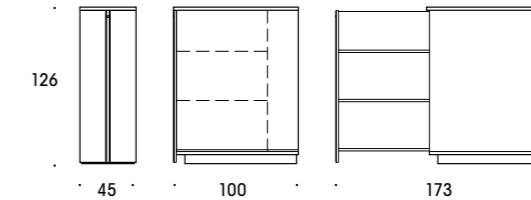

2061 Desk

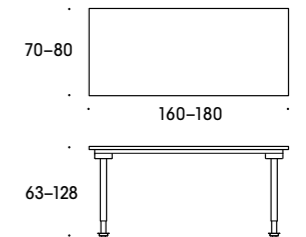

2840 Partition





Tables



Matrix



2063 Matrix T EL Pro
Electrically adjustable table



73-138

2110 Matrix Y



73

Matrix T manual



2056



66-81

Osio

Design Tapio Anttila



2526 T-leg



73

Dio



29072



73

Kantti

Design Tapio Anttila



7308



73

Oksa

Design Ilari Jääskeläinen



2555



72

2555



72

2556



90

Option

Design Antti Kotilainen



2400



73

2400



73

Ant



2500



73

Osio

Design Tapio Anttila



2526



73

2526



73

2527



110

Dio

29071



55

29072



73

29073



110

Scan

29057 General-purpose table



73

29057 Height adjustable table



73-110

29057 Stand-up height table



110

Moni

2523



73

2521



73

Matrix Y

Design Juha Lähti



2110



73

2111



90

Klik

Design Tapio Anttila



2534 Seminar table



73

2533 Foldable table



73

2531 Klik stackable seminar table



73

2551 Klik Pro



73

Move

2546 Gas spring table



71-112

2545 Folding table



73



Summa

Design Tapio Anttila



1501 Table top C8

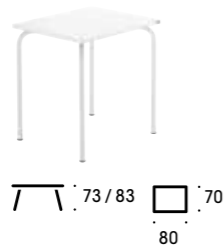

1501 Table top C14

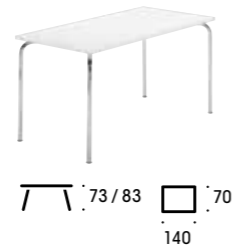
**Pisa table**

Design Desigence



1401



1401



1400

**7303**

7303

**Haiku**

Design Tapio Anttila



7310



7311 Raised table

**Osio sofa table**

Design Tapio Anttila



2525



2525



2525

**Sigur sofa table**

Design Saara Renvall



3745



3745



3745



See also Sigur sofas p. 127

Kivikko table

Design Henri Halla-aho



3753



3753



See also Kivikko seating p. 132

XO sofa table

Design Antti Kotilainen



7110



7110

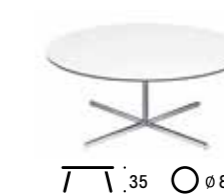

Swing sofa table

7144



7144 .50

Scan sofa table

29057



29057 .55

Diva sofa table

31087



31087 .38 O 70

31087



31087 .38 97 57 97

31087



31087 .45 115 65 115

Haiku sofa table

7312

Design Tapio Anttila



7312 .52

7313 Raised sofa table



7313 .65

7003 sofa table

7003



7003 .52



Storage



Tendo

Design Juha Lähti



22773 Storage tower



22773 Double sided storage tower



2753 Cabinet with sliding doors 120 cm



2753 Cabinet with sliding doors 80 cm



2752 Cabinet with sliding doors 120 cm



2743 Horizontal roll-front cabinet



2723 Roll-front cabinet + upper shelf unit



2742 Horizontal roll-front cabinet 120 cm



2724 Roll-front cabinet



2715 Cabinet with doors



2715 Shelf unit



Tendo Oppi

Design Juha Lähti & Antti Olin



1451 4D



1453 6G



1453 6J



1453 6E



1451 6Q



1455 6S



Tendo Mobili

Tendo AV



2732 Mobili



2733+B6 AV



Accessories

2790-575 Mail sorter



2790-520 Drawer with desk organiser



2793-500 Drawer set with frame



Tendo 43 cm deep elements



Meaning of symbols

- ☉ Storage unit also available with legs or castors
- ☐ Storage unit also available with legs

The cabinets are 80 cm wide unless otherwise stated.



Vakio

Design Juri Karinen



2708

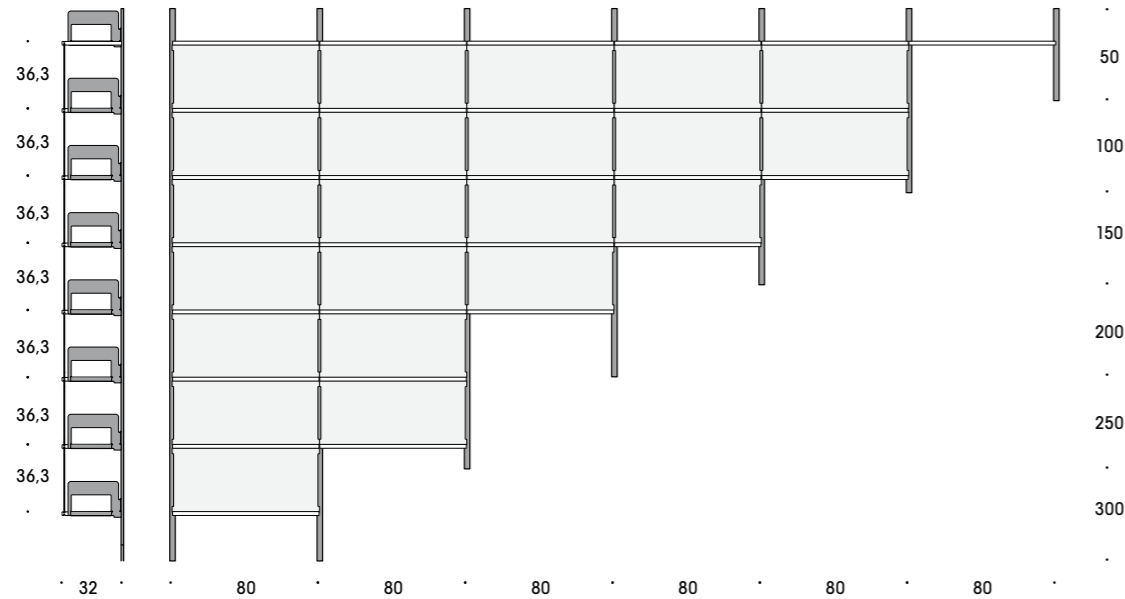

Doors

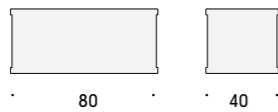

Ark

Design Henri Halla-aho



2700-



Modules

Locker depth 60 cm

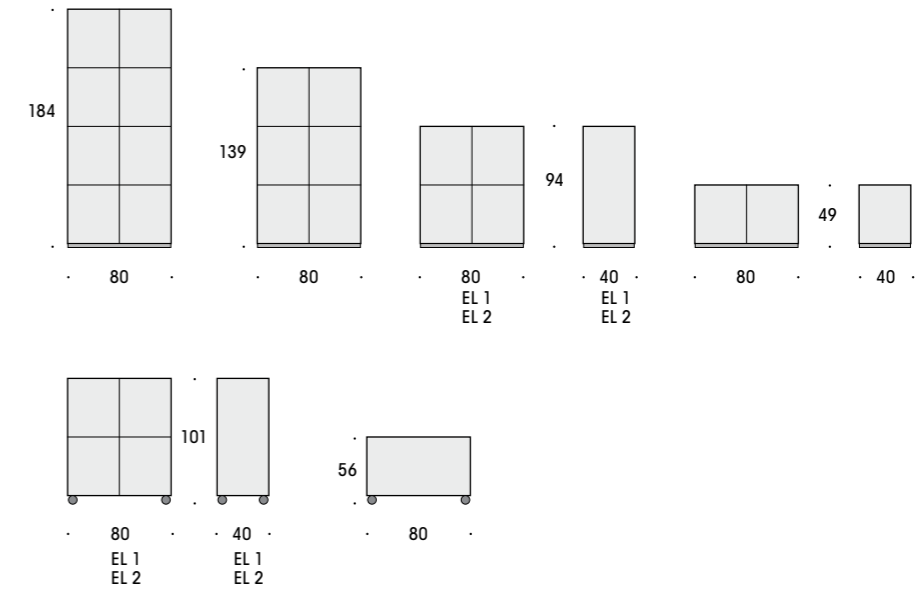

Features

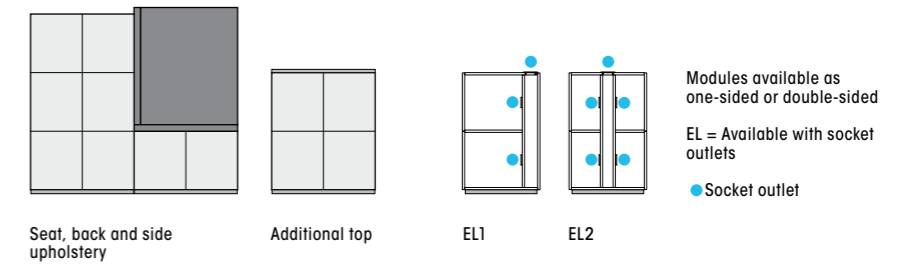

Modules available as one-sided or double-sided
EL = Available with socket outlets
● Socket outlet

Fuuga

Design Helorinne & Kallio



Examples of module selection

29550 Open module



29550 Open module with shelf



29550 Module with 2 doors



29550 Module with 4 doors



29550 Module with 2 drawers



29550 Module with 1 drawer



29550 Module with 2 doors



+ Bend leg 26 cm

29550 Module with 2 doors



+ String leg 26 cm

29550 Module with 2 doors



+ Groove leg 10 cm

29550 Module with 2 doors



+ Groove leg 26 cm

32-deep open modules

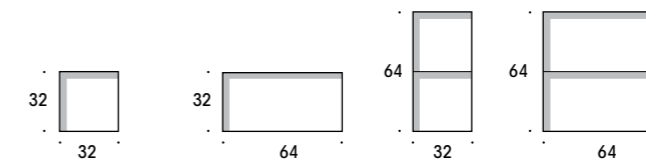

32-deep modules with door

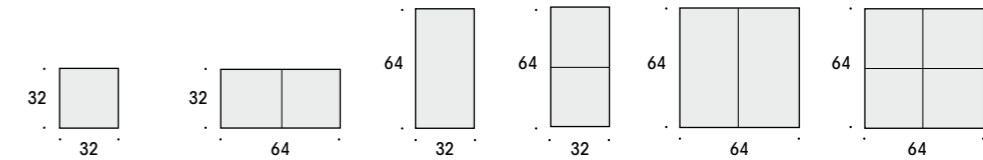

45-deep open modules

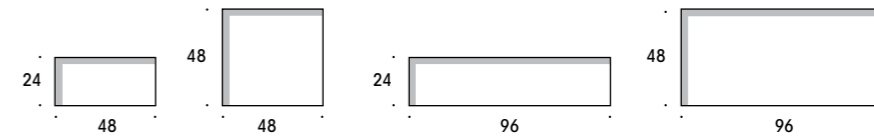

45-deep modules with doors

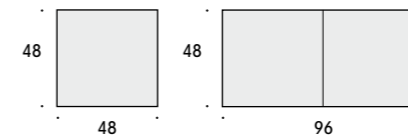

45-deep modules with drawers

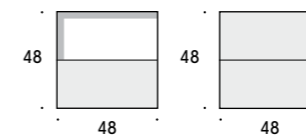
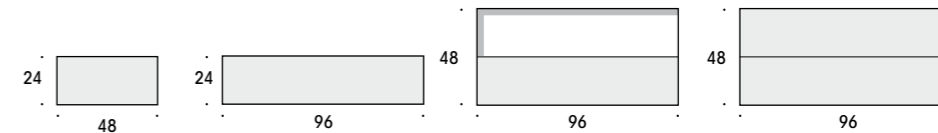

Modules are also available
26 cm or 10 cm legs.



Dividers

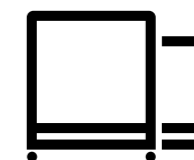

Mode dividers and front panels

Design Juha Lähti & Juri Karinen



2836 Mode front panel white

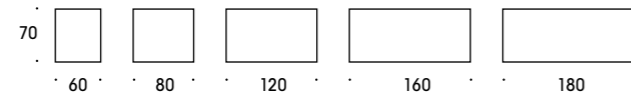

Panel thickness 1,6 cm

2836 Mode front panel upholstered

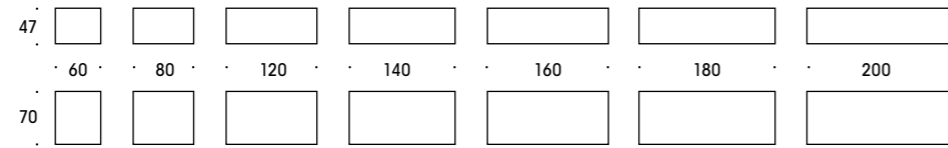

Panel thickness 2 cm

Mode and Mode Akusto divider and front panel fastening

66300



66301



66320



66311 Front panel upper support IM-789



66321 Front panel lower support IM-89



2839 Mode front panel fixing D IM-89



2 pieces 60-180 cm

2836 Mode Akusto front panel



With fastening D

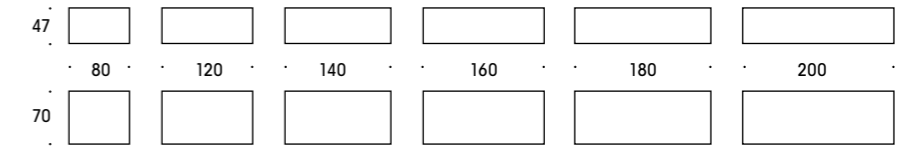

Panel thickness 4 cm

2831 Mode Akusto divider with legs



2831 Mode Akusto divider with legs



Colour options for Mode Akusto leg:

- graphite
- silver
- white
- black

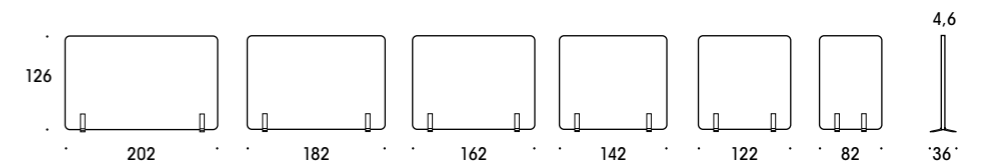

2831 Mode Akusto divider with castors



Colour options for Mode Akusto leg with castors:

- graphite / black castors
- silver / light grey castors
- white / white castors
- black / black castors

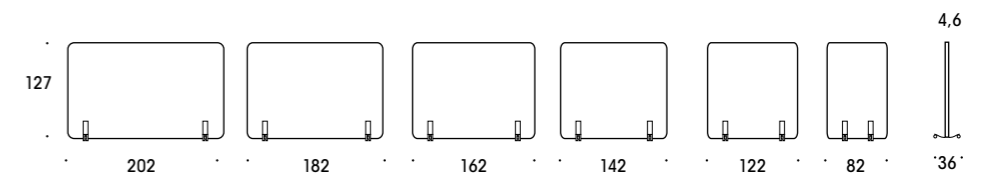

Mode Akusto front panel and divider system can be fixed with corner posts T, L, X. Dividers also come with velcro fastening on the sides.

Link Line

Design Raimo Räsänen



2828



2829

Link Line Akusto



Link Line 2828 and Link Line Akusto 2829 partition elements

Upper elements



Middle elements

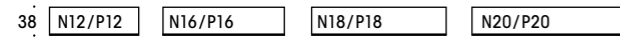

Bottom elements

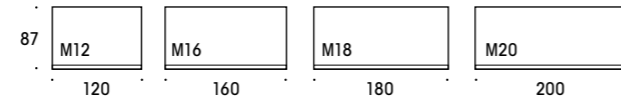

M, N = Fabric, P = Glass
Screen thickness 6 cm

Link

Design Raimo Räsänen



2824



2824



2825



Combinations of bottom and upper elements and window elements for Link partition screen

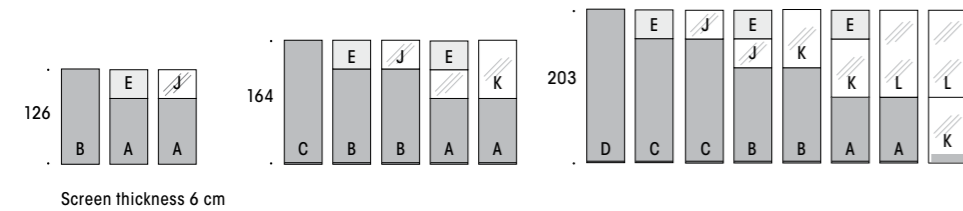

2823 Link door

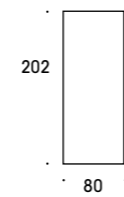

Link upper element E

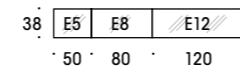

Link bottom elements A-D

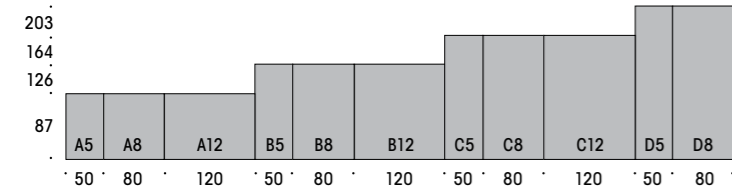

Link panels with window J-L

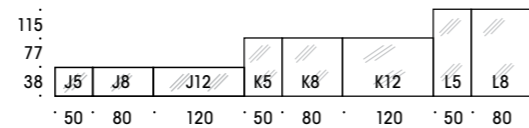

Air



2821

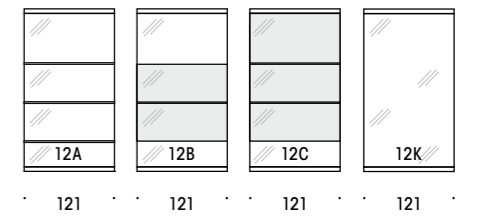
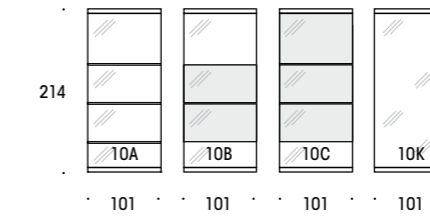
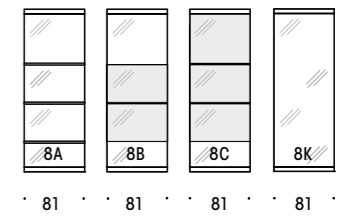
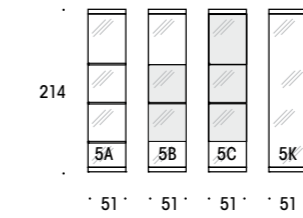

Air Acusto Box



Examples from a wide collection

Air Acusto Box acoustic insulation available in values
38 dB Rw construction
45 dB Rw construction

2821 XS 1



L 110, S 90, K 220

2821 XS 3



L 160, S 130, K 220

2821 M 2



L 210, S 210, K 220

2821 M 3



L 210, S 250, K 220

Woodland

Design Ivar Gestranus & Kevin Lahtinen



29898 High

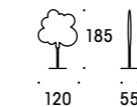

29898 Low

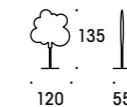



Accessories and decor



Desk top accessories



Mona monitor arm
 29038-505 ■ silver
 29038-506 □ white
 Maximum load 2–10 kg



Shown in image: 29039-400
 1 schuko, 4 x cable ports ■ black

Powerdot satellite

- 29039-400 1 schuko, 4 x cable ports ■ black
- 29039-401 1 schuko, 4 x cable ports □ white
- 29039-405 1 schuko, 4 x cable ports, adjustable ■ black
- 29039-410 1 schuko, 1 data, 1 USB charger, adjustable ■ black
- 29039-411 1 schuko, 1 data, 1 USB charger, adjustable □ white
- 29039-415 1 schuko, 1 HDMI, 1 USB port, adjustable ■ black

Available with UK power socket

Powerdot accessories

For models 29039-405, -410, -411 and -415



Metal cover

- 29039-460 ■ silver
- 29039-461 □ white
- 29039-462 ■ black

Metal frames

- 29039-470 ■ silver
 - 29039-471 □ white
 - 29039-472 ■ black
- For 1 Powerdot

- 29039-475 ■ silver
 - 29039-476 □ white
 - 29039-477 ■ black
- For 2 Powerdots

- 29039-480 ■ silver
 - 29039-481 □ white
 - 29039-482 ■ black
- For 4 Powerdots

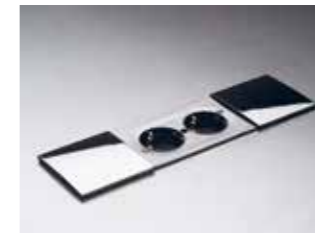

Shown in image: 29038-732 2 x schuko ■ black



Due power socket

Available with
 2 x schuko

- stainless steel
- white
- black



Shown in image: 29038-700
 1 x schuko ■ stainless steel

Pix power socket

Available with
 1 x schuko
 1 x UK power socket
 1 x HDMI
 1 x USB charger

- stainless steel
- white
- black



Shown in the image:
 29045-720 + 29045-810
 4 x schuko, 4 x net, VGA, USB, audio, HDMI
 ■ brushed stainless steel

Bi-Box modular power socket

- Bi-Box2** 29045-700 3 x schuko, 2 x net
- Bi-Box3** 29045-705 2 x schuko, net, VGA, audio, HDMI
- Bi-Box4** 29045-710 4 x schuko, 4 x net, 4 x USB
- Bi-Box5** 29045-715 4 x schuko, net, VGA, audio, HDMI
- Bi-Box6** 29045-720 4 x schuko, 4 x net, VGA, USB, audio, HDMI

Bi-Box short

- 29045-800 ■ brushed stainless steel
- 29045-805 □ white

Bi-Box long

- 29045-810 ■ brushed stainless steel
- 29045-815 □ white



Shown in image: 29038-820
2 x schuko + USB charger ■ silver

Power Frame modular power socket

Available with
2 x schuko + RJ45
2 x UK power socket + RJ45
2 x schuko + HDMI
2 x UK power socket + HDMI
2 x schuko + USB charger

■ silver
□ white
■ black



Shown in image: 29038-855
2 x schuko + RJ45 ■ silver

Power Frame Cover modular power socket

Available with
2 x schuko + RJ45
2 x UK power socket + RJ45
2 x schuko + HDMI
2 x UK power socket + HDMI
2 x schuko + USB charger

■ silver
□ white
■ black



Socket column

29030-500	2 x 4 schuko, 2 x RJ45	□ white
29030-501	2 x 4 schuko, 4 x RJ45	□ white
29030-510	2 x 4 schuko, 2 x RJ45 L	□ white
29030-511	2 x 4 schuko, 4 x RJ45 L	□ white
29030-520	2 x 4 schuko, 2 x RJ45 T/120°	□ white
29030-521	2 x 4 schuko, 4 x RJ45 T/120°	□ white
29030-530	2 x 4 schuko, 2 x RJ45 X	□ white
29030-531	2 x 4 schuko, 4 x RJ45 X	□ white

Either independent columns with their own flange leg base, or as part of Link and Link Line screen system.

Standing mat



Balance Spot standing mat

35050-500 ■ grey
35050-501 ■ dark grey
64 x 46 x 3 cm

Organiser



R-Eco organiser

29028-500
3 waterproof baskets.
43 x 30 x 45 cm

Reception desk



Reception counter

2095

The Reception counter can be assembled in a variety of combinations. Combining sitting and standing height counters in different ways creates a wide variety of alternatives. The front panels are made of glass in the standard model. The desks are placed inside the Reception counter. Always contact an Isku expert to design a functional combination.

Lighting

**LED Disonic desk light**

29035-500 white
29035-501 black

USB-reloadable, automatic power cut-off, 5-step brightness adjustment and color temperature adjustment.

**Valovoima bright light**

29036-510 white
Design Harri Koskinen

57,5 x 50 cm
LED table lamp/certified bright light device with dimmer, 4000K, aluminum.

**Level S and L acoustic pendant light**

29036-514 (Level S) grey
29036-515 (Level L) grey

Design Muotohiomo
36 x 29 x 50 cm (S)
100 x 15 x 50 cm (L)
LED, 4000K, felt-like material 100% recycled PET, L-size can be used as a space divider.

**Fiber 900 and 1200 pendant light**

29036-519 (Fiber 900) grey
29036-520 (Fiber 1200) grey

Design Lars Vejen
14 x 88 x 6 cm (900)
14 x 118 x 6 cm (1200)
LED, 4000K, fiber cement and white acrylic.

**Diamond pendant light**

34836-63 \varnothing 42 cm opal
34836-64 \varnothing 60 cm opal

Design Jonas Hakaniemi
 \varnothing 42 cm and \varnothing 60 cm

**LasKos pendant light**

34836-80 opal
34836-81 creme
34836-82 black

Design Kristiina Lassus
 \varnothing 33 cm

**Lootus pendant light**

34836-94 opal
34836-95 grey
34836-96 purple
34836-97 brown

Design Jukka Korpihete
 \varnothing 62 cm

**Loisto table light**

29551-530 white
29551-531 green/white
29551-532 grey/white

Design Jukka Korpihete
height 54,5 cm, stand \varnothing 17,2 cm
lamp shade \varnothing 28,5 cm

**Soihitu table light**

29551-500 white
29551-501 black
29551-502 sand

Design Jukka Korpihete
25 x 30 x 50 cm

**Soihitu floor light**

29551-540 white
29551-541 black
29551-542 sand

Design Jukka Korpihete
73 x 50 x 180 cm

**Halo Small ceiling light**

29551-520 white
29551-521 black
29551-522 sand

Design Jukka Korpihete
height 25,5 cm, \varnothing 70 cm

**Halo Large ceiling light**

29551-510 white
29551-511 black
29551-512 sand

Design Jukka Korpihete
height 22,5 cm, \varnothing 100 cm

**Tip pendant light**

29036-400 \varnothing 40 cm white
29036-401 \varnothing 40 cm black and white
29036-500 \varnothing 60 cm white
29036-501 \varnothing 60 cm black and white

Design Tapio Anttila
LED, 4000K, acrylic

**Tip floor light**

29036-505 \varnothing 60 cm white

Design Tapio Anttila
LED, 4000K, acrylic

Clothes stands

**Post stand**

29021

Design Mikko Laakkonen

Metal. Colors: silver, graphite, white, green, black

**Arctic stand**

29020

Design Ismo Mankonen

Metal. Color: silver / black, graphite / black

**Lotus stand**

33524

Metal. Rotating top.

Color: silver, graphite

**Lobby clothes stand system**

29022

Design Jukka Setälä

90/120 x 40/60 x 190 cm

Colors: Birch, grey

**Lobby Tech clothes stand system**

29023

Design Jukka Setälä

90/120 x 40/55 x 190 cm

Metal and glass. Color: light grey

Writing boards

**Mood Wall**

29693

100 x 100, 150 x 100, 200 x 100 cm,

white and colored.

Magnetic glass surface.

**Mood Flow Mobile**

29693

Design Christian Halleröd

65 x 19,6 cm, white and colored.

Magnetic glass surface.

Carpets

Size S shape

**pOmpUp carpet**

35000-5.. pOmpUp ORIGINAL

35000-6.. pOmpUp ORIGINAL ENTRANCE

100 x 145 (S), 122 x 250 (M), 193 x 300 cm (L), black/melange, grey/melange, brown/melange.

Size M shape



35000-7.. pOmpUp EXCLUSIVE

35000-8.. pOmpUp EXCLUSIVE ENTRANCE

90 x 47 (S), 122 x 62 (M), 193 x 97 cm (L), red, black, grey, light grey.

Size L shape



Entrance shape



35000-9.. pOmpUp SUPER

35000-9.. SUPER ENTRANCE

90 x 47 (S), 122 x 62 (M), 193 x 97 cm (L) wide selection of colors in the custom-order collection.

Size S shape

**OCTA S-carpet**

35000-4..

EXCLUSIVE 90 x 180

red, black, grey, light grey

35000-4..

SUPER 90x180 cm, wide selection of colors in the custom-order collection.

Size M+ shape

**OCTA M+ -carpet**

35000-4..

EXCLUSIVE 130 x 325

35000-4..

SUPER 130x325 cm

wide selection of colors in the custom-order collection.

Size L shape

**OCTA L -carpet**

35000-4..

EXCLUSIVE 190x190 cm

red, black, grey, light grey

35000-4..

SUPER 190x190 cm, wide selection of colors in the custom-order collection.

**tWIN A carpet**

35000-3..

EXCLUSIVE 350 x 195 cm, red, black, grey,

light grey

SUPER 350 x 195 cm, wide selection of colors in the dense-pile custom-order collection.

**tWIN B carpet**

35000-3..

EXCLUSIVE 195 x 115 cm, red, black, grey,

light grey

SUPER 195 x 115 cm, wide selection of colors in the dense-pile custom-order collection.

**GO outdoor carpet**

35000..

CIRCLE S 100 x 100 cm

CIRCLE L 180 x 180 cm

SEMI-CIRCLE S 50 x 100 cm

SEMI-CIRCLE L 90 x 180 cm

Wide selection of colors (17 colours).

Acoustic elements

**Duo**

35010-5.. INNOturf SMARTpackDUO

Ø 25 x 0,2 (XS), Ø 33 x 0,2 (S), Ø 40 x 0,2 (M) and Ø 59 x 0,2 cm (L), white, black or custom print.

**Mind**

35010-5.. INNOturf SMARTpackMIND

Ø 40 x 0,2 (M) and Ø 59 x 0,2 mm (L), white, black, natural or custom print.

Silk plants

**Cypress 170 cm**

29696-420 Cubico pot white
 29696-421 Cubico pot dark grey
 Pot height 75 cm, plant height 140 cm,
 total height apx. 170 cm

**Buxus cone 150 cm**

29696-400 Cubico pot white
 29696-401 Cubico pot dark grey
 Pot height 56 cm, plant height 125 cm,
 total height apx. 150 cm

**Buxus ball 125 cm**

29696-430 Cubico pot white
 29696-431 Cubico pot dark grey
 Pot height 75 cm, plant height 50 cm,
 total height apx. 125 cm

**Thuja ball 125 cm**

29696-440 Cubico pot white
 29696-441 Cubico pot dark grey
 Pot height 75 cm, plant height 50 cm,
 total height apx. 125 cm

**Decorative grass 150 cm**

29696-540 Cubico pot white
 29696-541 Cubico pot silver
 29696-542 Cubico pot black
 29696-543 Cubico pot graphite grey
 Pot height 56 cm, plant height 130 cm,
 total height apx. 150 cm

**Spear Sansevieria 110 cm**

29696-550 Cylindrus pot white
 29696-551 Cylindrus pot black
 29696-552 Cylindrus pot dark grey
 Pot height 43 cm, plant height 95 cm,
 total height apx. 110 cm

**Mother-in-law's tongues 110 cm**

29696-710 Pure Square Divider white
 29696-711 Pure Square Divider dark grey
 Pot height 80 cm, plant height 70 cm,
 total height apx. 110 cm

High plants

*Suitable for outdoor use,
 plants are wind resistant and
 fitted with water drainage.

Indoor plants**Rubber tree 220 cm**

29696-560 Cubico pot white
 29696-561 Cubico pot silver
 29696-562 Cubico pot black
 29696-563 Cubico pot graphite grey
 Pot height 75 cm, plant height 170 cm,
 total height apx. 220 cm

**Rubber tree 200 cm**

29696-530 Cubico pot white
 29696-531 Cubico pot silver
 29696-532 Cubico pot black
 29696-533 Cubico pot graphite grey
 Pot height 56 cm, plant height 170 cm,
 total height apx. 200 cm

Trees**Zamioculcas 65 cm**

29696-905 Quadro pot white
 29696-906 Quadro pot silver
 29696-907 Quadro pot black
 29696-908 Quadro pot graphite grey
 Pot height 21 cm, plant height 55 cm,
 total height apx. 65 cm

**Mother-in-law's tongues 55 cm**

29696-920 Balconera pot white
 29696-921 Balconera pot dark grey
 Pot height 19 cm, plant height 45 cm,
 total height apx. 55 cm

Low plants**Agave 55 cm**

29696-900 Quadro pot white
 29696-901 Quadro pot silver
 29696-902 Quadro pot black
 29696-903 Quadro pot graphite grey
 Pot height 21 cm, plant height 45 cm,
 total height apx. 55 cm

**Mother-in-law's tongue 50 cm**

29696-910 Quadro pot white
 29696-911 Quadro pot silver
 29696-912 Quadro pot black
 29696-913 Quadro pot graphite grey
 Pot height 21 cm, plant height 45 cm,
 total height apx. 50 cm

**Decorative grass 40 cm**

29696-930 Balconera pot white
 29696-931 Balconera pot dark grey
 Pot height 19 cm, plant height 30 cm,
 total height apx. 40 cm



Materials

Interior design has become a part of the company's identity. Material selections are used to create personal and appealing facilities giving a good first impression of the company.

The furniture and material selections of public spaces must ensure wear resistance, easy maintenance and safety matters according to the regulations.

When the decor and materials of facilities are designed in an inspiring and efficient manner it will, at its best, have a positive impact on the coping and efficiency of the personnel. A well-designed space stands out.

Learn more about our extensive selection of standard materials at www.isku.com

kvadrat

Lauritzon's

camira

Gabriel

Symbols

Materials

The materials available for a product are indicated with the symbols listed below. The material can refer to one or more products in the product family.



Solid wood
Varnished, stained
or painted



Veneer
Varnished,
stained or
painted



Laminate



Leather



Fabric



Metal frame



Plastic



Recycled material



Glass



Health collection
Antimicrobial
surface materials
available

Additional features

The additional features available for products are indicated with the symbols listed below. The feature can refer to one or more products in the product family.



Available with
castors or rollers



Available in
stackable form



Available with
row link fittings



Available with
removable or
spare covers



Available extended
or with height
adjustment



Available with a
rocking mechanism



Available with
wheelchair dimensions

Dimensions

The dimensions are given in centimetres (cm) in order of width, depth and height or with the symbols listed below.

Seats

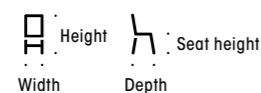

Tables

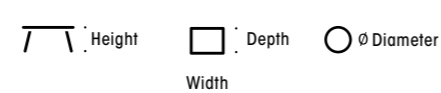

Antimicrobial materials

Antimicrobial materials based on silver and copper eliminate microbes and thus reduce the transmission of microbial pathogens through contact surfaces. Antimicrobial furniture is ideal for all public facilities with an elevated risk of infection, such as healthcare facilities, service housing, day-care centres, schools and social premises at offices.

+ For products marked with this symbol, the metal, upholstery and wood materials are available with antimicrobial properties. The property remains throughout the product's service life.

Upholstery

For spare or removable covers, we recommend the laminated fabric in the Gabriel Step collection, available in 12 standard colours. The fabric can withstand industrial laundry processes.

For fully antimicrobial fixed upholstery, we recommend Camira Halcyon fabrics.

In an operating environment that does not place any special requirements on the fabric, products can be upholstered with any upholstery fabric in Isku's fabric range.

In the product catalogue, products are presented with main images. More information about the products, materials and features is available on the product cards as well as at www.isku.com.

Woods and veneers

The standard solid woods and veneers are birch, beech and oak. Veneers are primarily always stained on beech. (Check the product card for the woods available for the product.)

Laminate

We offer a standard laminate range of 13 patterns and a selection of antimicrobial laminates. Both are available with ABS or cast edges (check the product card for the availability of cast edges for the product).

Metals

In addition to the standard colours, customer-specific colours according to the specification are available as a special delivery. (Check the product card for the product's standard colours.)

Guarantee

We do not automatically grant a guarantee for fabrics and surface treatments outside of our standard collection.

Desk and table top collection

The tops are made of 26 mm thick furniture board or MDF. Asymmetrical tops are shown as left-handed versions. Right-handed versions are also available. The beech veneered tops can be stained with Isku standard furniture stains. Veneered EL and P table tops are made of MDF board with bevelled and laquered edges. Lam 215 and lam 230 EL and P table tops have ABS edging strips. Some table tops are available with laser edging strips.

Antimicrobial table tops

All table tops can be made with antimicrobial surfaces for projects.

Antimicrobial table top collection.

Tops are 26 mm thick laminated or brass surfaces. Edges: cast edges or veneered.

↔ Direction of the veneer in veneered tops
 --- Beveled edge

Edge options

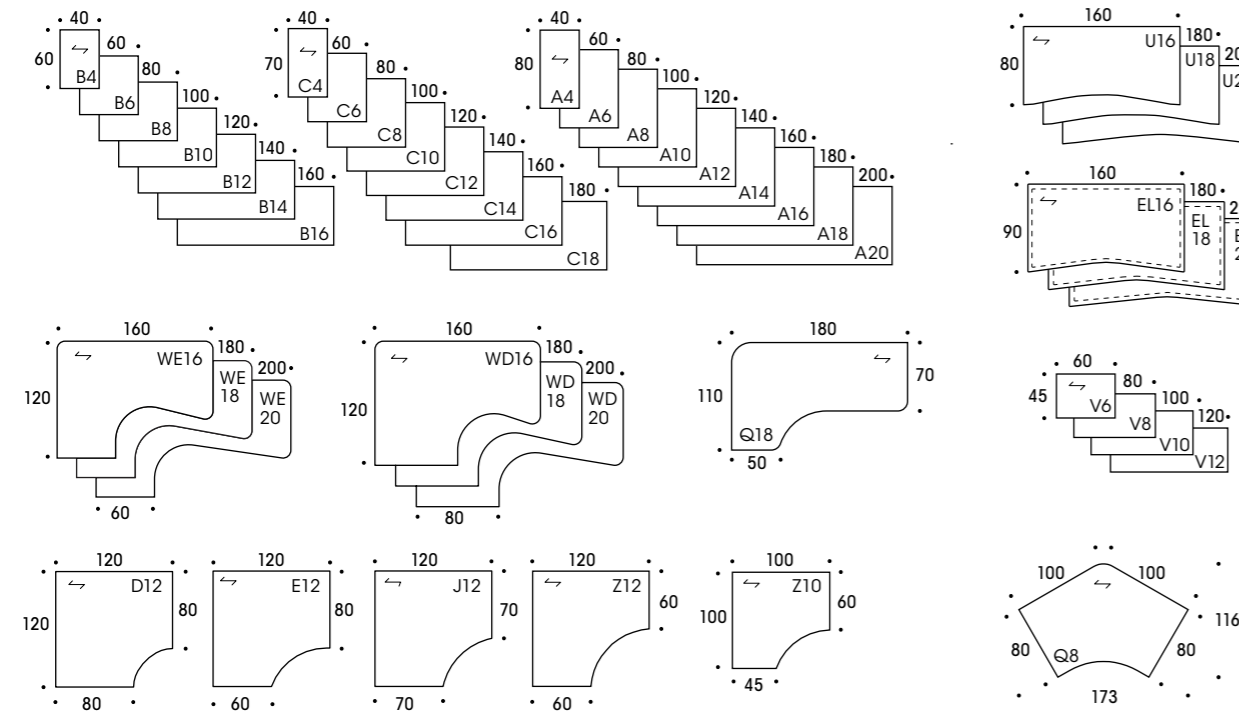
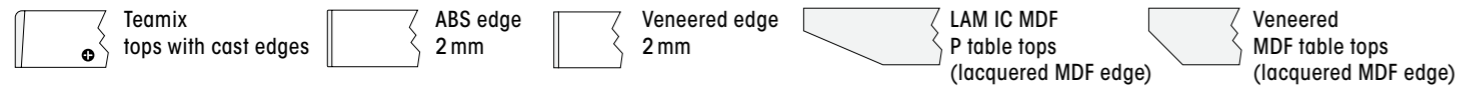

Team work table tops

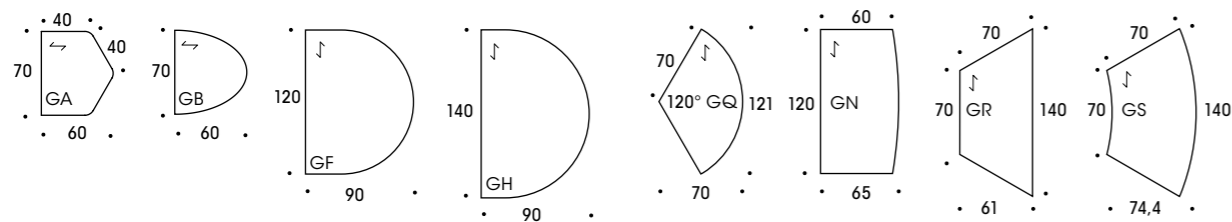

Round and oval tops

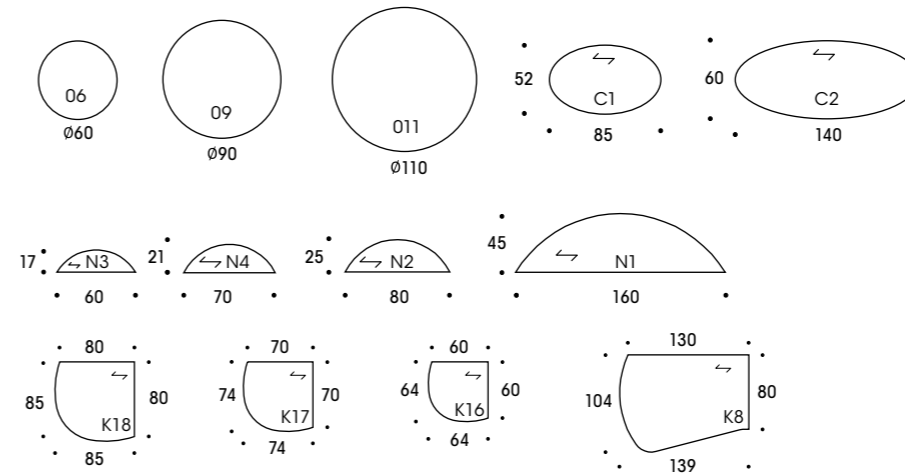

Conference table tops

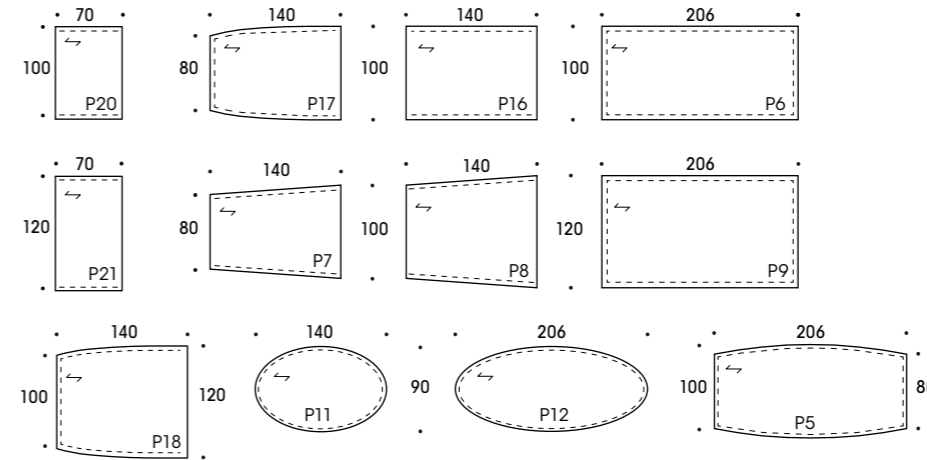

Top with cast edges (Teamix)

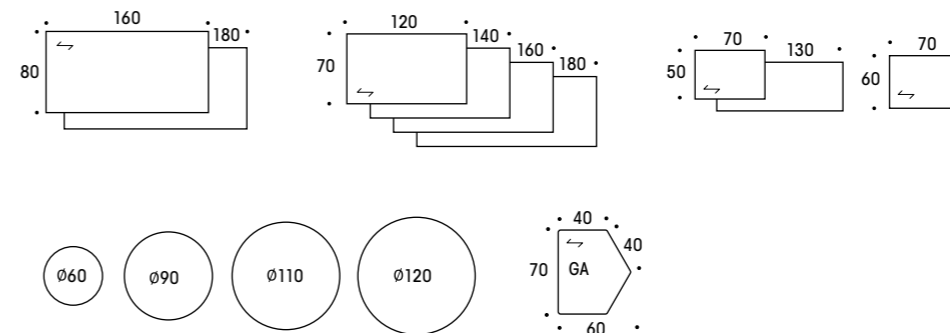

	Tops					Edges		
	Birch	Beech	Oak	Lam 230	Lam 215	Veneer 2 mm	LAM IC MDF	Veneered MDF
A4	x	x	
A6	x	x	
A8-20	x	x	
B4	x	x	
B6-16	x	x	
C1	x	x	
C2	x	x	
C4	x	x	
C6	x	x	
C8	x	x	
C10	x	x	
C12-18	x	x	
D12	x	x	
Z10	x	x	
Z12	x	x	
E12	x	x	
WE16	x	x	
WE18	x	x	
WE20	x	x	
WD16	x	x	
WD18	x	x	
WD20	x	x	
EL16	x	x	x
EL18	x	x	x
EL20	x	x	x
J12	x	x	
K8	x	x	
K16	x	x	
K17	x	x	
K18	x	x	
N1	x	x	
N2	x	x	
N3	x	x	
N4	x	x	
O6	x	x	
O9	x	x	
O11	x	x	
P5	x	x	x
P6	x	x	x
P7	x	x	x
P8	x	x	x
P11	x	x	x
P12	x	x	x
P16	x	x	x
P17	x	x	x
P18	x	x	x
P19	x	x	x
P20	x	x	x
P21	x	x	x
Q8	x	x	
Q18	x	x	
U16	x	x	
U18	x	x	
U20	x	x	
V6	x	x	
V8	x	x	
V10	x	x	
V12	x	x	

Products

3016 office chair 147
 7003 sofa table 161
 7303 table 158

A
 Acoustic elements 187
 Aino Pro 115, 125
 Air 177
 Air Acusto Box 177
 Alias 124
 Amphi 25, 133
 Ant 39, 155
 Ark 26, 169
 Aura 124

B
 Big Hug 18, 123
 Bulldog 49

C
 Casa 138
 Clothes stands 186
 Concorde 123
 Cubio 123

D
 Desk top accessories 180
 Dio 154, 156
 Diva 139
 Diva sofa table 160
 Duo 43, 94, 122
 Duo Lounge 22, 122
 Dyyini 126

F
 Free 61, 137
 Fuuga 170

G
 Geneve Plus Pro 49, 129
 Giant Donut 135

H
 Haiku 158
 Haiku sofa table 160

I
 IKI 63, 97, 125
 ILOA 71, 73, 146
 Inkoo Pro 59, 99, 130
 Inkoo Pro High 53, 130
 Isku Classic T EL 150
 Isku Easy T EL 47, 148, 150
 Isku Style T EL 45, 65, 150

K
 Kaari 57, 131
 KAB Control room seating
 105, 144
 Kantti 41, 155
 Kivikko 49, 53, 59, 65, 132
 Kivikko table 132, 159
 Klik 157

L
 Lighting 184
 Lightness 35, 155, 121
 Link 176
 Link Line 176
 Logo 119

M
 Matot 187
 Matrix I 151
 Matrix T EL Pro 71, 154
 Matrix T manual 150, 154
 Matrix Y 154, 157
 Matti 115, 119
 Metro 37, 122
 Minus 118
 MK23 73, 159
 Mode 65, 174
 Mode Akusto 65, 174, 172
 Moni 156
 Move 157
 Mukula 134
 Muvman 147

O
 Oksa 155
 Ongo 47
 Ongo Free 147
 Option 43, 155
 Organisers 183
 Organo 123
 Osio 152, 154, 156
 Osio sofa table 159

P
 Pisa table 158
 Poiju 57
 PRO 6 120

R
 Reception desk 183
 Roope 125
 Rudolf 31, 33, 65, 73,
 115, 116, 178

S
 Salli saddle chair 145
 Scan 156
 Scan sofa table 160
 Sera 124
 Signum 41, 118
 Sigur 127
 Sigur sofa table 127, 159
 Silk plants 188
 Standing mats 183
 Step+ 69, 143
 Still 45, 65, 67, 140, 142
 Still Meeting 47, 142
 Stone 151
 Summa 158
 Swing sofa table 160
 Syke 51, 128

T
 Taiko 121
 Tendo 45, 162, 164
 Tendo AV 165
 Tendo Mobili 165
 Tendo Oppi 165
 Tere 55, 126
 The Box Lounger 43, 135
 Time 136
 Tuoli 50 115, 121
 Tutto 21

V
 Vakio 29, 168
 Versio 39, 120

W
 Woodland 177
 Writing boards 186

X
 XO sofa table 159

Isku Interior showrooms in Finland**Espoo**

Kuifinmäentie 26
02240 Espoo
interior.hki@isku.com
+358 29 086 4201

Joensuu

Pilkontie 3
80130 Joensuu
interior.joensuu@isku.com
+358 29 086 4751

Jyväskylä

Tourulantie 13
40100 Jyväskylä
interior.jkl@isku.com
+358 29 086 4901

Kokkola

Pitkäsillankatu 17
67100 Kokkola
interior.kokkola@isku.com
+358 29 086 3901

Kouvola

Tommolankatu 7
45130 Kouvola
mikko.uusitalo@isku.com
+358 29 086 4643

Kotka

Jumalniementie 4
48600 Kotka
interior.kotka@isku.com
+358 29 086 4648

Kuopio

Kartanonkatu 4 A
70700 Kuopio
interior.kuopio@isku.com
+358 29 086 4701

Lahti

Mukkulankatu 19
15210 Lahti
interior.lahti@isku.com
+358 29 086 3000

Lappeenranta

Myllymäenkatu 34
53550 Lappeenranta
interior.lpr@isku.com
+358 29 086 4601

Mikkeli

Graanintie 4
50190 Mikkeli
interior.mikkeli@isku.com
+358 29 086 4371

Oulu

Taka-Lyötyn aukio 4
90140 Oulu
interior oulu@isku.com
+358 29 086 4801

Pori

Itsenäisyydenkatu 1-5
28100 Pori
interior.pori@isku.com
+358 29 086 4661

Rovaniemi

Vierustie 5
96320 Rovaniemi
interior.rovaniemi@isku.com
+358 29 086 4961

Seinäjoki

Rengastie 4
60120 Seinäjoki
interior.seinajoki@isku.com
+358 29 086 3931

Tampere

Sammonkatu 47
33540 Tampere
interior.tampere@isku.com
+358 29 086 4501

Turku

Satakunnantie 162
20320 Turku
interior.turku@isku.com
+358 29 086 4401

Vaasa

Kivihaantie 4
65300 Vaasa
interior.vaasa@isku.com
+358 29 086 4871

Vantaa

Martinkyläntie 47
01720 Vantaa
interior.hki@isku.com
+358 29 086 4201

Isku Home stores also selling furniture for public spaces in Finland**Kajaani**

Veturitie 1
87100 Kajaani
koti.kajaani@isku.com
029 086 4940

Rauma

Kairakatu 1
26100 Rauma
koti.rauma@isku.com
029 086 4460

Tornio

Pakkahuoneenkatu 1
95400 Tornio
koti.tornio@isku.com
029 086 4990

Varkaus

Käpykankaantie 2
78850 Varkaus
koti.varkaus@isku.com
029 086 4730

Isku Interior subsidiaries and sales offices abroad**Isku Interior Oy export**

Mukkulankatu 19
P.O.Box 240
FI-15101 LAHTI
Finland
+358 29 086 3000
contact@isku.com
www.isku.com/en

SWEDEN

Per-Åke Karlsson
per-ake.karlsson@isku.com
+46 733 990775
www.isku.com/sv

NORWAY

**Isku Interiør AS/
Norengros**
+47 908 43 000
firmapost@isku.no
www.isku.com/en

Visiting Address:
Isku Interiør AS
Drammensveien 130 inng. C 6
0277 OSLO

Postal address:
Isku Interiør AS
Postboks 4152 Sjølyst
0217 OSLO

DENMARK
Standard Systemer ApS

(wholesaler)
Kobbelvænget 74
2700 Brønshøj
COPENHAGEN
Denmark
+45 3826 4900
info@standardsystem.dk
www.isku.com/en

ESTONIA

Isku Baltics OÜ
Pärnu mnt. 139f
EE11317 TALLINN
Estonia
+372 6 556 055
isku@isku.ee
www.isku.com/et

LATVIA

Isku Baltics OÜ
Brīvības street 197
LV-1039 RIGA
Latvia
+371 67606157
+371 29204244
isku.riga@isku.lv
www.isku.com/lv

LITHUANIA

Isku Baltics OÜ
P. Lukšio g. 21
LT-09132 VILNIUS
Lithuania
+370 603 47426
info@isku.lt
www.isku.com/lt

POLAND

**Isku Interior Sp. z o.o.
Oddział w Polsce**
Prosta Tower, 5th Floor, Prosta 32
00-838 WARSAW
Poland
+48 503 134 668
www.isku.com/pl

RUSSIA

Isku Interier SP
B.Sergiyevsky per. 10
107045 MOSCOW
Russia
+7 495 926 15 31
contact@isku.com
www.isku.com/ru

Isku Interier SP

B.Sampsonievsky pr. 4-6, lit.A
194044 St.PETERSBURG
Russia
+7 812 448 11 38
contact@isku.com
www.isku.com/ru

MIDDLE EAST

Isku Middle East DMCC
AG-25-E, Silver Tower, Cluster I
Jumeirah Lake Towers
P.O. Box 114494 DUBAI
U.A.E
+971 439 87977
iskume@isku.com
www.isku.com/en

Isku Interior is represented internationally.
Contact your local Isku office at
www.isku.com

Isku Interior Oy
Mukkulankatu 19, PL 240
15101 Lahti, FINLAND
+358 29 086 3000
www.isku.com

© Isku Interior Oy
All rights reserved.

Art direction and layout: Marion Robinson

Photography: Tuomas Heikkilä / Isku Interior
and suppliers

Printing: Kirjapaino Kari Ky, Jyväskylä, 2017
The papers used for this catalogue are from
sustainably managed forests.



PEFC Certified

This product is from
sustainably managed
forests and controlled
sources

www.pefc.co.uk

Since 1928



www.isku.com